

Legend:
 △ Aircraft primary tripod jack location
 □ Aircraft auxiliary tripod jack location
 ○ Aircraft axle jack location

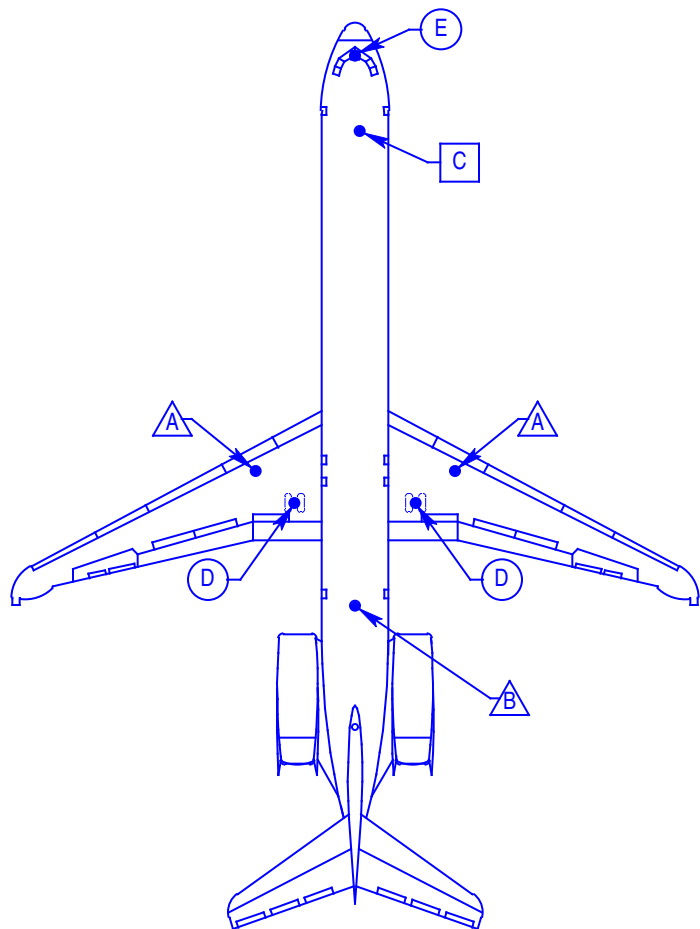

**FOR ALTERNATE JACK SELECTIONS, REFER TO
 "RECOMMENDED MALABAR AIRCRAFT JACK MODELS" CHART**

AIRCRAFT DATA						MALABAR JACK MODELS AND DATA					
REF.	LOCATION & SERVICE	MAX. JACK LOAD	MIN. HT.	MAX. HT.	DISTANCE BETWEEN TIRES	MODEL	CAP.	MIN. HT.	HYD. LIFT	SCR. EXT.	MAX. HT.
A	Main Wing: Gear Swing	22.1 (20.0)	60.0 (1524)	86.4 (2195)		8826	35 (31.8)	60 (1524)	44 (1118)	16 (406)	120 (3048)
	Main Wing: Oleo Removal			92.0 {1} (2337)							
B	Aft: Gear Swing	9.95 (9.0)	47.4 (1204)	71.4 (1814)		7212B	12 (10.9)	30 (762)	40 (1016)	8 (203)	78 (1981)
	Aft: Oleo Removal			77.1 {1} (1958)							
C	Forward: Gear Swing	5.4 (4.9)	32.7 (831)	62.4 (1585)		7210B	10 (9.1)	25 (635)	36 (914)	6 (152)	67 (1702)
	Forward: Oleo Removal			68.1 {1} (1730)							
D	MLG: Routine	28.8 (26.1)	13.8 (350)	19.8 {3} (503)	9.2 (234)	832R	35 (31.8)	7 (178)	12 (305)	3 (76)	22 (559)
	MLG: Flats		9.5 (241)		2.0 (51)						
E	NLG: Routine	5.8 (5.3)	9.1 (231)	12.5 {3} (318)	6.0 (152)	642S	10 (9.1)	6 (152)	8.25 (210)	3 (76)	17.25 (438)
	NLG: Flats		6.6 (168)		2.2 (56)						

Notes:

- **Caution:** Aircraft manufacturer's specifications and instructions must be followed. In the event of contradiction between aircraft manufacturer's specifications and Malabar's, aircraft manufacturer's specifications will prevail.
 - Capacities shown in tons and (metric tons). Dimensions shown in inches and (millimeters).
 - Tripod jack point heights are based on:
 - Main & nose landing gear strut oleos at normal operating empty weight (OEW).
 - Main gear tires H41 x 15 - 19.
 - Nose gear tires 26 x 6.6.
 - All tires at normal inflation pressure.
 - Shock struts deflated.
- {1} Dimensions apply without wheels and tires.
 {2} Maximum aircraft weight should not exceed 46 tons when jacking with tripod jacks.
 {3} Allows 2" ground clearance.

MALABAR INTERNATIONAL SIMI VALLEY, CALIFORNIA
<h1>BOEING 717</h1> <h2>AIRCRAFT / JACK DATA</h2>
REVISED DATE: APRIL 3, 2002