



Legend:  Aircraft primary tripod jack location
 Aircraft auxiliary tripod jack location
 Aircraft axle jack location



**FOR ALTERNATE JACK SELECTIONS, REFER TO
 "RECOMMENDED MALABAR AIRCRAFT JACK MODELS" CHART**

AIRCRAFT DATA						MALABAR JACK MODELS AND DATA					
REF.	LOCATION & SERVICE	MAX. JACK LOAD	MIN. HT.	MAX. HT.	DISTANCE BETWEEN TIRES	MODEL	CAP.	MIN. HT.	HYD. LIFT	SCR. EXT.	MAX. HT.
A	Main Wing: Gear Swing	120.3 (109.1)	148.40 (3769)	184.30 (4681)		8811B {1}	120 (108.9)	116 (2946)	76 (1930)	28 (711)	220 (5588)
	Main Wing: Oleo Removal			207.50 (5271)							
B	Forward: Gear Swing	30.6 (27.8)	93.30 (2370)	125.40 (3185)		733A	40 (36.3)	87 (2210)	72 (1829)	26 (660)	185 (4699)
	Forward: Oleo Removal			140.30 (3564)							
C	Wing Tip: Gear Swing	4.0 (3.6)	178.00 (4521)	192.00 (4877)		8487A {2}	5 (4.5)	160 (4064)	32 (813)	8 (203)	200 (5080)
D	MLG: Routine	64.0 (58.1)	16.00 (406)	23.50 (570)	27.10 (688)	65P10AR	65 (59)	10.25 (260)	11 (279)	4.75 (121)	26 (660)
	MLG: Flats		9.50 (241)		11.00 (279)	65L4.5 {3}	65 (59)	4.5 (114)	17.5 (445)	0	22 (559)
E	NLG: Routine	30.5 (27.7)	13.00 (330)	19.00 (483)	8.90 (226)	65P10AR	65 (59)	10.25 (260)	11 (279)	4.75 (121)	26 (660)
	NLG: Flats		7.10 (180)		0						

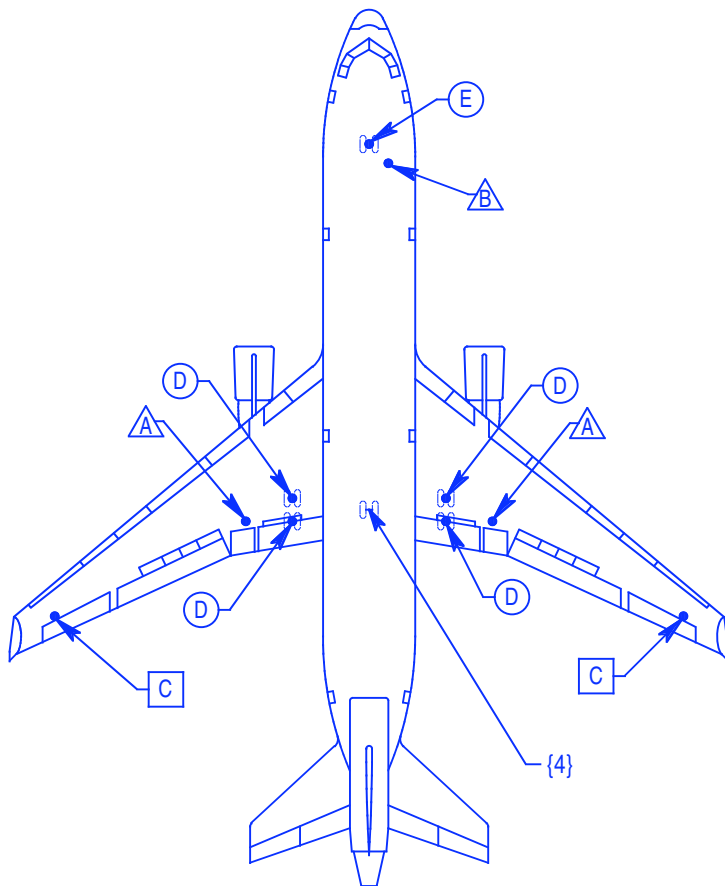
Notes:

- **Caution:** Aircraft manufacturer's specifications and instructions must be followed. In the event of contradiction between aircraft manufacturer's specifications and Malabar's, aircraft manufacturer's specifications will prevail.
- Capacities shown in tons and (metric tons). Dimensions shown in inches and (millimeters).
- Tripod jack point heights are based on:
 - Main & nose landing gear strut oleos fully deflated.
 - Main gear tires H54 x 21.0-24.
 - Nose gear tires 40 x 15.5-16.
 - All tires at normal inflation pressure.

{1} Specify with 116" low height leg kit

{2} Use Douglas adapter p/n DZZ7320. Adapter adds 12" (305 mm) to jack minimum height.

{3} Lift provided by 65P10 or 65P10AR axle jack.

{4} For CLG jacking, de-pressurize strut prior to jacking and use axle jack models 65P10 or 65P10AR.

MALABAR INTERNATIONAL
 SIMI VALLEY, CALIFORNIA

DOUGLAS MD 11
AIRCRAFT / JACK DATA

REVISED DATE: APRIL 2, 2013