

12 Ton Axle Jack

Model 642S



The Model 642S Axle Jack is a 12 ton capacity, three stage hydraulic jack designed primarily for use in jacking main and/or nose landing gear of various aircraft. The jack consists of a three stage cylinder assembly, hydraulic reservoir and hand pump assembly. Lifting handle is also supplied for ease of handling.

Model 642S is built to withstand harsh environmental conditions and rugged use, and to provide many years of continuous service. Our customers are guaranteed a quality product with each purchase and are assured of our continued product support whenever and wherever the need arises.

Standard Features:

- Hard chrome plated cylinder and plunger bores
- Extension screw and hand pump parts are plated to resist corrosion
- Manual hand pump
- Skydrol resistant paint (safety yellow)
- Factory proof load @ 150% of rated capacity
- 1 year standard warranty
- Fully enclosed shipping container

Optional Features:

- Customer specified paint color
- Repair kit

12 Ton Axle Jack

Model 642S

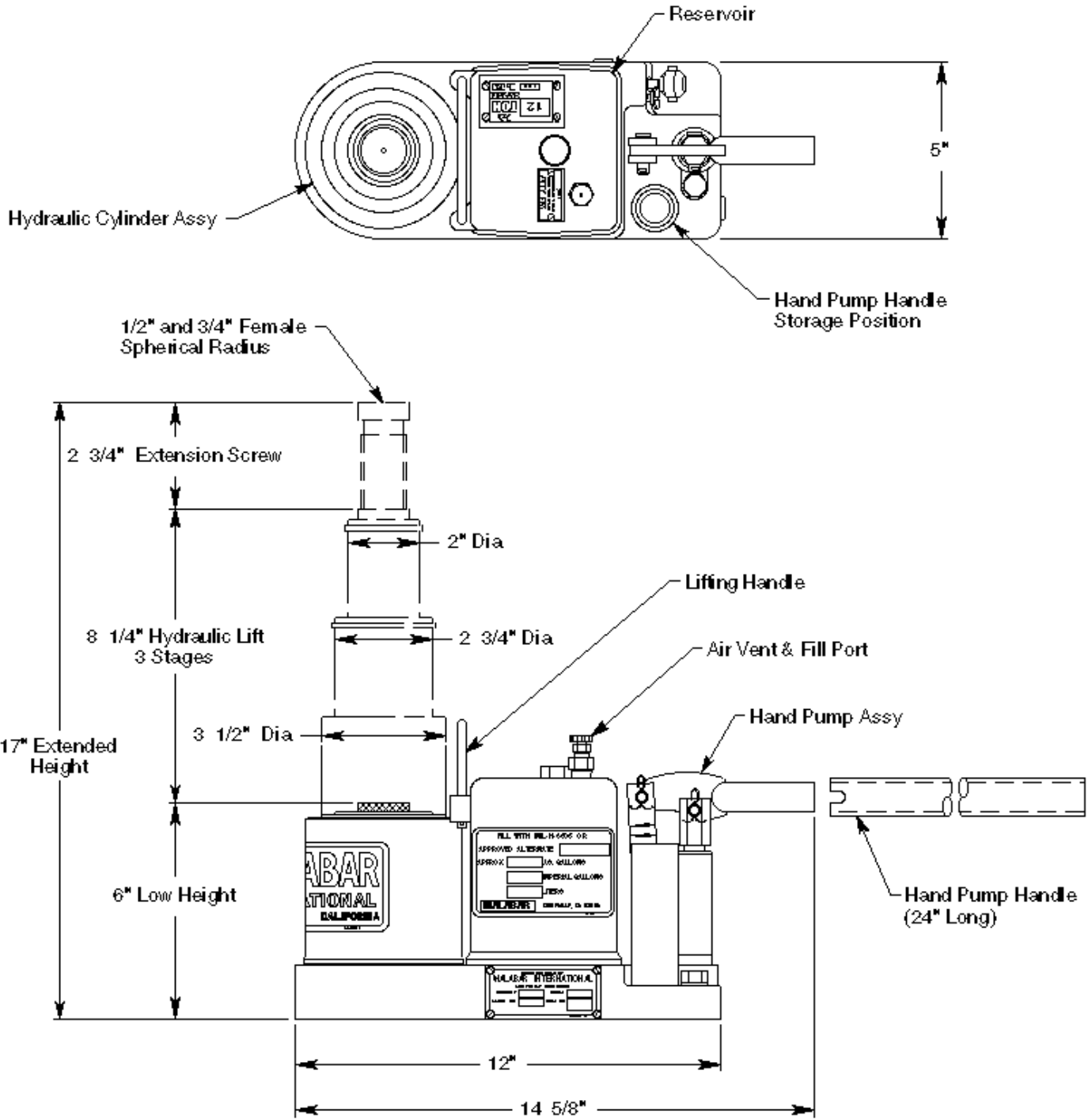

For more information contact: sales@malabar.com

12 Ton Axle Jack

Model 642S

Specifications:

Rated Capacity	12 tons (10.9 m. tons)
Side Load.....	15% of vertical load
Low Height.....	6 in. (152 mm)
Hydraulic Lift.....	8.25 in. (210 mm)
Extension Screw.....	2.75 in. (70 mm)
Total Extended Height.....	17 in. (432 mm)
Oil Pressure at Rated Capacity.....	6162 psig (433 kg/sq cm)
Safety Pop-off Valve set at:.....	13.2 tons (12.0 m. tons)
Proof Load.....	18 tons (16.3 m. tons)
Reservoir Capacity.....	0.4 gallons (1.5 liters)
Hydraulic Fluid.....	MIL-PRF-5606 or equivalent
Approximate Jack Net Weight.....	40 lbs. (18 kg)

Model 642S Typical Aircraft Applications:

Nose Landing Gear	Main Landing Gear
A318, A319, A320, A321, ARJ21, ATR42, ATR72, Avro RJ, B717, B737, BAC1-11, BAE146, CL601, CL602, CL604, CL605, CL610, CS100, CS300, D228, D328, Dash 7, Dash 8, DC9, DHC5, DHC6, Embraer Legacy 450/500/600/650, ERJ-135/-145/-170/-175/-190/-195, F27, F28, F50, F100, Falcon 10, Falcon 20, Falcon 50, Falcon 100, Global Express, HS125, Jetstar, Learjet 45, Learjet 75, MD80, MD90, S330, S360, SF340	ATR42, ATR72, D228, D328, Dash 7, Dash 8, DHC5, DHC6, Dornier 228/328, Embraer Legacy 450/500/600/650, F27, F50, Falcon 10, Falcon 20, Falcon 50, Falcon 100, Jetstar, Learjet 45, Learjet 75, S330, S360, SF340

Optional Equipment Codes:

(Specify with order)

- SPC: Special Paint Color (yellow is standard)
- 642SPK: Repair Kit

Shipping Data:

NOTE: Model 642S jack is shipped in a fully enclosed shipping container.

Length inches (mm)	Width inches (mm)	Height inches (mm)	Weight lbs (kg)
25 (635)	10 (254)	17 (432)	44 (20)