

Axle Jack Transporter

Model 8817A



Aircraft axle jacks are frequently subjected to significant wear and tear in today's fast paced aircraft maintenance environment. Most axle jacks are built to withstand tow speeds up to 5 mph on smooth ramp surfaces. Excessive speed and/or uneven road or ramp surfaces accelerate wear and tear on the axle jack. Axle jack running gear components (casters, wheels, towbars and under carriage linkage), load gauges and jack cylinder bases are often damaged beyond economical repair even during the first year of operation. Labor costs and repair parts cost can easily approach several hundred dollars per year per jack.

The Model 8817A Axle Jack Transporter virtually eliminates towing damage to axle jacks and is universal for all 45-95-ton Malabar axle jacks. Foam filled tires are included, which eliminate flats due to punctures and provide a cushioned ride. The transporter is lightweight with rugged tubular frame construction. The balanced design means only one person is required to load and unload the axle jack.

Model 8817A is built to withstand harsh environmental conditions and rugged use, and to provide many years of continuous service. Our customers are guaranteed a quality product with each purchase and are assured of our continued product support whenever and wherever the need arises.

Standard Features:

- 16 inch diameter foam filled tires
- Tow handle with 3 inch lunette eye for towing
- All unpainted parts are plated to resist corrosion
- Skydrol resistant paint (safety yellow)
- 1 year standard warranty
- Shipment on domestic skid

Optional Features:

- Customer specified paint color
- Export crating

Axle Jack Transporter

Model 8817A

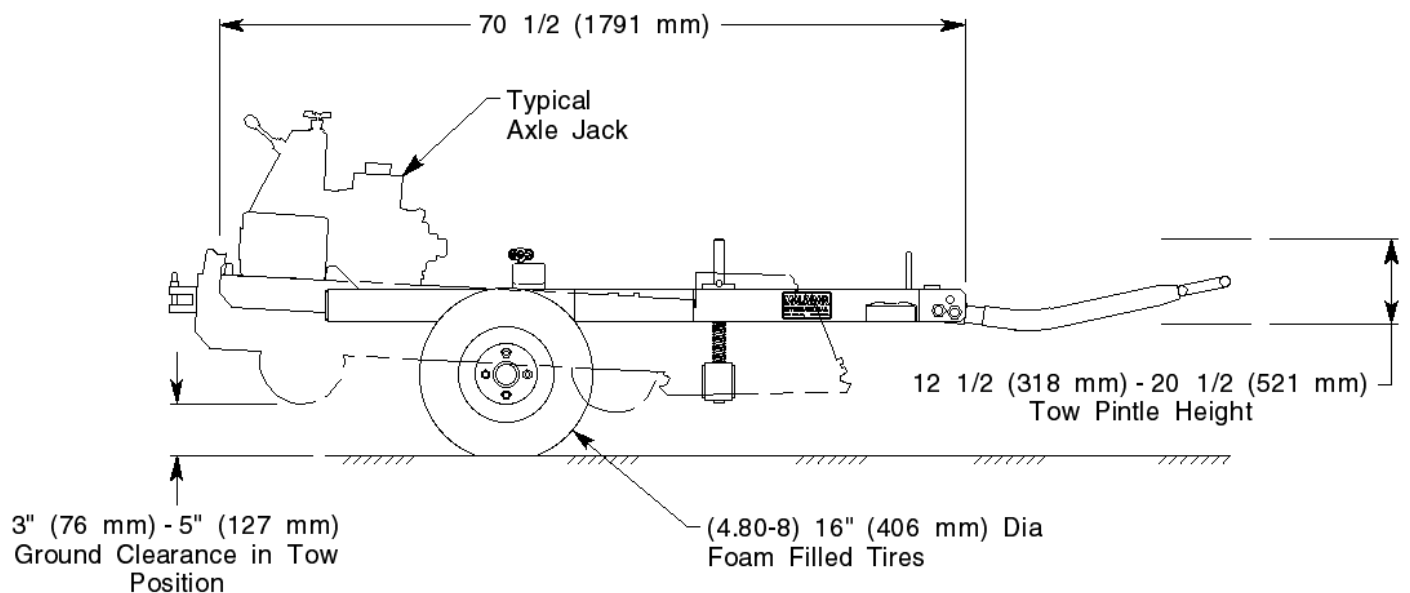
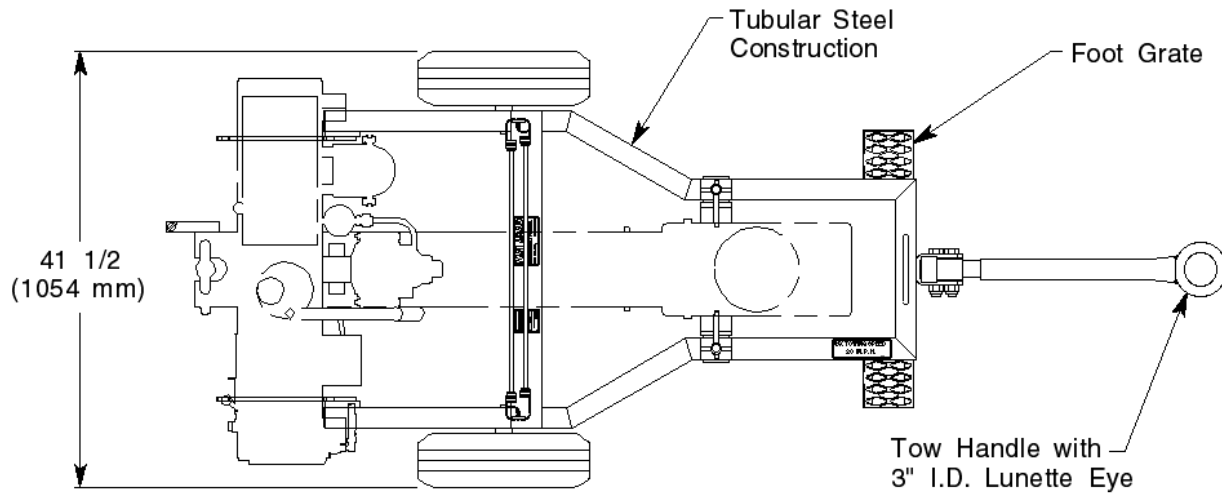

Axle Jack Transporter

Model 8817A

Specifications:

Unit Weight..... 150 lbs (68 kg)
 Unit Weight (with axle jack) 650 lbs (295 kg)
 Maximum towing Speed..... 20 mph (32.2 km/h)
 Recommended Tow Vehicle Pintle Height 12.5 inches (318 mm) to 20.5 inches (521 mm)

Model 8817A Axle Jack Transporter Carries the Following Malabar Axle Jack Models:

50P9AR, 60P9, 65P9, 65P9AR, 60P10, 65P10, 65P10AR,
85P10AR, 8842, 8899, 8900, 95P10AR

Optional Equipment Codes:

(Specify with order)

SPC: Special Paint Color

Packaging Codes and Options:

(Specify with order)

-: Domestic Skid
 EC: Export Crate (Additional Cost)

Shipping Data:

NOTE: Unless otherwise specified, Model 8817A Axle Jack Transporter is shipped on a wood skid.

Packaging Code	Length inches (mm)	Width inches (mm)	Height inches (mm)	Weight lbs (kg)
-	72 (1829)	42 (1067)	27 (686)	250 (113)
EC	74 (1880)	46 (1168)	30 (762)	400 (181)