

MODEL 8844A LANDING GEAR STRUT SERVICE UNIT

STRUT SERVICE UNIT INCLUDES:

- Towable unit with integral Reservoir and tubular Frame
- Poly filled Tires and 3" Lunette Tow Eye
- Conveniently located Operator Panel for easy strut servicing
- Baffled cylindrical Reservoir with Fluid Sights, Fillcap, Dessiccant Breather, Strut Vent system, Drain Valve and Cleanout
- Air Operated Hydraulic Pump and Vacuum Degassing system
- Connections for customer provided regulated nitrogen and air
- Suction and Return Filtration
- Vacuum Gauge and Analog Pressure Gauge
- Two Service Hoses with strut Safety Chucks on Hose Racks
- 1 Year Warranty
- Skydrol Resistant Paint (white)

STANDARD OPTIONS:

- Two Retractable Hose Reels with 25' long Service Hoses

Model 8844A is built to withstand harsh environmental conditions, rugged use and to provide many years of continuous service. Our customers are guaranteed a quality product with each purchase and are assured of our continued product support whenever and wherever the need arises.

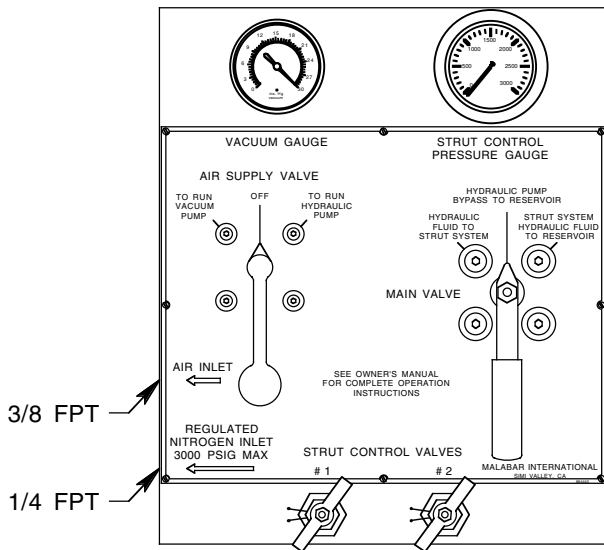

Control Panel

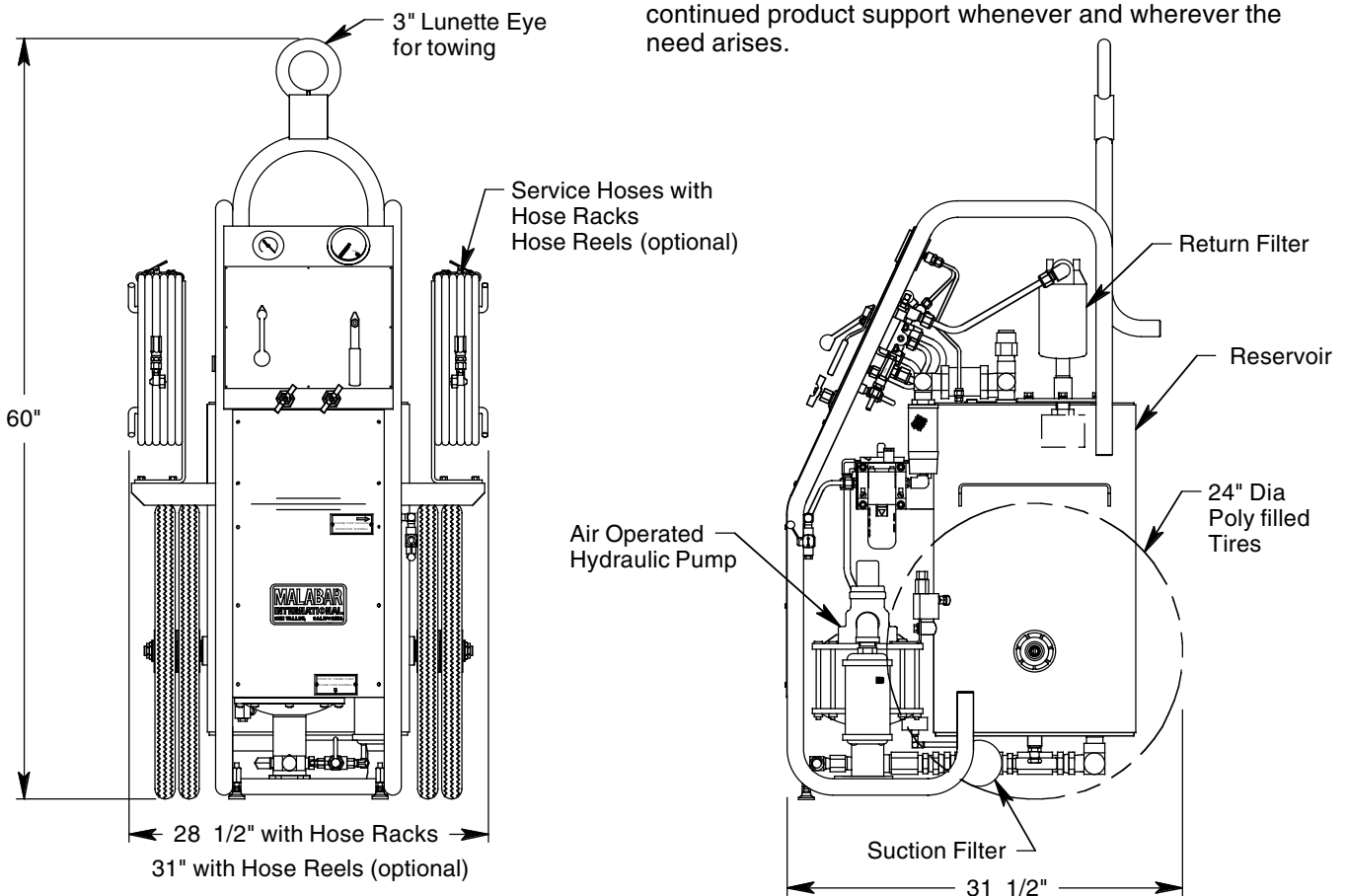

See Reverse Side for Specifications, Options & Shipping Data

MODEL 8844A LANDING GEAR STRUT SERVICE UNIT

SPECIFICATIONS

Air Inlet: 90-110 psig (6.3-7.7 kg/sq cm)
 Regulated Nitrogen Inlet: 3000 psig max (210 kg/sq cm)
 Hydraulic Fluid: MIL-H-5606 or equivalent
 Hydraulic Bypass Relief Valve set at: 3000 psig (211 kg/sq cm)
 Reservoir Capacity: 18 gallons (68 liters)
 Fluid Pump Air Consumption: 56 scfm @ 100 psig
 Fluid Pump Nitrogen Consumption: 62 scfm @ 100 psig
 Fluid Delivery Rate: 2 gpm @ 1500 psig
 Suction Fluid Filter: 10 micron nominal
 Return Fluid Filter: 25 micron nominal
 Vacuum Degassing System: 20 inches Hg
 Service Hose (2 each): 25 ft (7620 mm)
 Maximum Towing Speed: 20 mph (32 km/h)
 Unit Weight w/o optional equipment (dry): 265 lbs (120 kg)
 Unit Weight w/o optional equipment (wet): 405 lbs (184 kg)

Model 8844A Landing Gear
Strut Service Unit
Shown in Tow Configuration

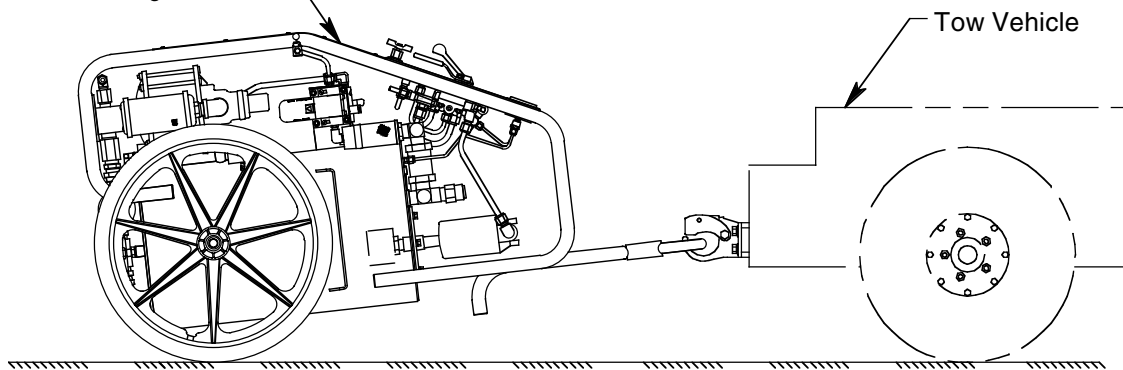

MODEL 8844A TYPICAL AIRCRAFT APPLICATIONS

All Narrow Body and Wide Body Aircraft Single or Dual Chamber Struts

OPTIONAL EQUIPMENT CODES: (Specify at time of order)

HR: Two Retractable Hose Reels with 25' long hoses

SHIPPING DATA

NOTE: Unless otherwise specified, Model 8844A is shipped on a wood skid with an enclosed cover.

Length inch (mm)	Width inch (mm)	Height inch (mm)	Weight lbs (kg)
70 (1778)	45 (1143)	39 (991)	380 (172)

MALABAR International

Issue: 6/06

PLANT: 220 WEST LOS ANGELES AVENUE, SIMI VALLEY, CALIFORNIA 93065 • (805) 581-0116 • FAX (805) 584-1624
 MAIL: P.O. BOX 367, SIMI VALLEY, CALIFORNIA 93062 • E-mail: sales@malabar.com • Web site: http://www.malabar.com