

# Landing Gear Strut Service Unit

## Model 8844B



The Model 8844B Landing Gear Strut Service Cart delivers hydraulic fluid and nitrogen to service both single and dual chamber strut aircraft landing gear. The Model 8844B allows quick emptying of used hydraulic fluid and nitrogen from the strut chambers, then refilling and recharging with fresh hydraulic fluid and nitrogen, all without jacking the aircraft. Because jacking is not required, the time required to perform this important maintenance procedure is dramatically reduced.

Model 8844B is built to withstand harsh environmental conditions, rugged use and to provide many years of continuous service. Our customers are guaranteed a quality product with each purchase and are assured of our continued product support whenever and wherever the need arises.

### Standard Features:

- Towable unit with integral reservoir and tubular frame
- Poly filled tires and 3" lunette ring
- Conveniently located operator panel for easy strut servicing
- Baffled cylindrical dual reservoir (8.5 gallons for clear fluid and 7 gallons for waste fluid) with fluid sights, fill cap, desiccant breather, strut vent system, drain valve and cleanout
- Air operated hydraulic pump and vacuum degassing system
- Connections for customer provided regulated nitrogen and air
- Suction and return filtration
- Vacuum gauge and analog pressure gauge
- Two service hoses with strut safety chucks on hose racks
- Skydrol resistant paint (white)
- 1 year standard warranty

### Optional Features:

- Two retractable hose reels with 25' long service hoses
- Return fluid sight
- Customer specified paint color

# Landing Gear Strut Service Unit

## Model 8844B

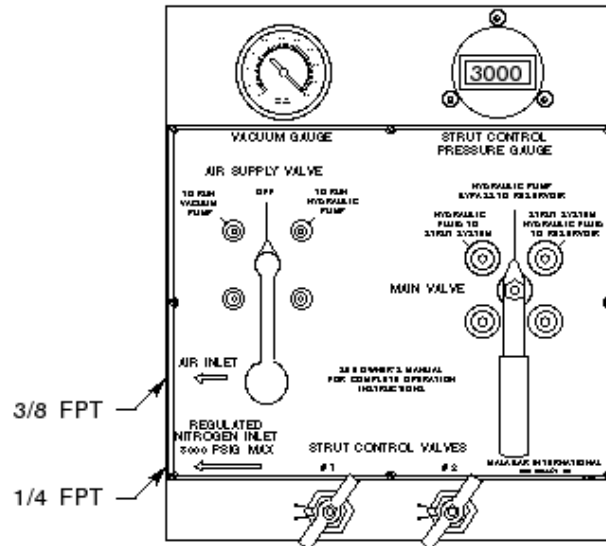

Control Panel

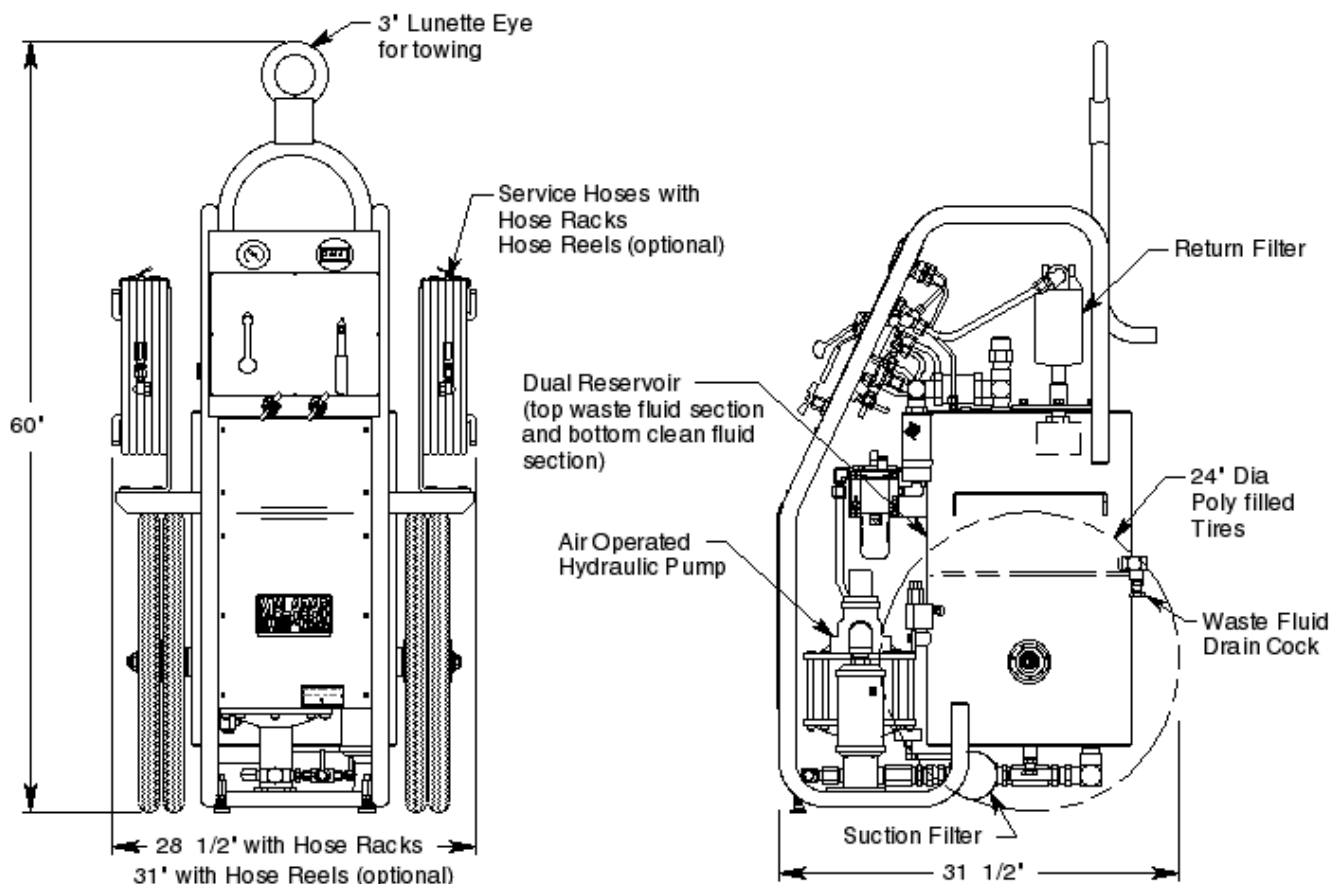

For more information contact: [sales@malabar.com](mailto:sales@malabar.com)

# Landing Gear Strut Service Unit

## Model 8844B

### Specifications:

Air Inlet .....	90-110 psig (6.3-7.7 kg/sq cm)
Regulated Nitrogen inlet.....	3000 psig max (210 kg/sq cm)
Hydraulic Fluid.....	MIL-PRF-5606 or equivalent
Hydraulic Bypass Relief Valve set at .....	3000 psig (211 kg/sq cm)
Clean Reservoir Capacity .....	8.5 gallons (32 liters)
Waste Reservoir Capacity.....	7.0 gallons (26 liters)
Fluid Pump Air Consumption .....	56 scfm @ 100 psig
Fluid pump Nitrogen Consumption.....	62 scfm @ 100 psig
Fluid Delivery Rate .....	2 gpm @ 1500 psig
Suction Fluid Filter .....	10 micron nominal
Vacuum Degassing System.....	20 inches Hg
Service Hose (2 each).....	25 ft (7620 mm)
Maximum towing Speed.....	20 mph (32 km/h)
Unit Weight w/o optional equipment (dry) .....	265 lbs (120 kg)
Unit Weight w/o optional equipment (wet) .....	405 lbs (184 kg)

### Model 8844B Typical Aircraft Applications:

All Narrow Body and Wide Body Aircraft Single or Dual Chamber Struts

### Optional Equipment Codes:

*(Specify at time of order)*

- HR: Two retractable hose reels with 25' long hoses
- FS: Return fluid sight
- SPC: Special paint color

### Shipping Data:

NOTE: Unless otherwise specified, Model 8844B is shipped on a wood skid with an enclosed cover.

Length inches (mm)	Width inches (mm)	Height inches (mm)	Weight lbs (kg)
70 (1778)	45 (1143)	39 (991)	380 (172)