

# Axle Jack Transporter

## Model 8867

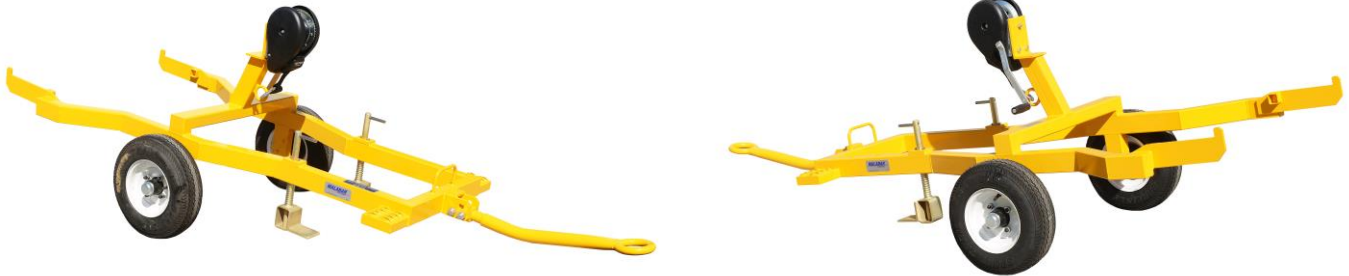

Aircraft axle jacks are frequently subjected to significant wear and tear in today's fast paced aircraft maintenance environment. Most axle jacks are built to withstand tow speeds up to 5 mph on smooth ramp surfaces. Excessive speed and/or uneven road or ramp surfaces accelerate wear and tear on the axle jack. Axle jack running gear components (casters, wheels, towbars and under carriage linkage), load gauges and jack cylinder bases are often damaged beyond economical repair even during the first year of operation. Labor costs and repair parts cost can easily approach several hundred dollars per year per jack.

The Model 8867 Axle Jack Transporter virtually eliminates towing damage to axle jacks. Foam filled tires are included, which eliminate flats due to punctures and provide a cushioned ride. The transporter is lightweight with rugged tubular frame construction. The balanced design means only one person is required to load and unload the axle jack.

Model 8867 is built to withstand harsh environmental conditions and rugged use, and to provide many years of continuous service. Our customers are guaranteed a quality product with each purchase and are assured of our continued product support whenever and wherever the need arises.

### Standard Features:

- Manual winch for loading/unloading axle jack
- 16 inch diameter foam filled tires
- Tow handle with 3 inch lunette eye for towing
- All unpainted parts are plated to resist corrosion
- Skydrol resistant paint (safety yellow)
- 1 year standard warranty
- Shipment on domestic skid

### Optional Features:

- Customer specified paint color
- Export crating

# Axle Jack Transporter

## Model 8867

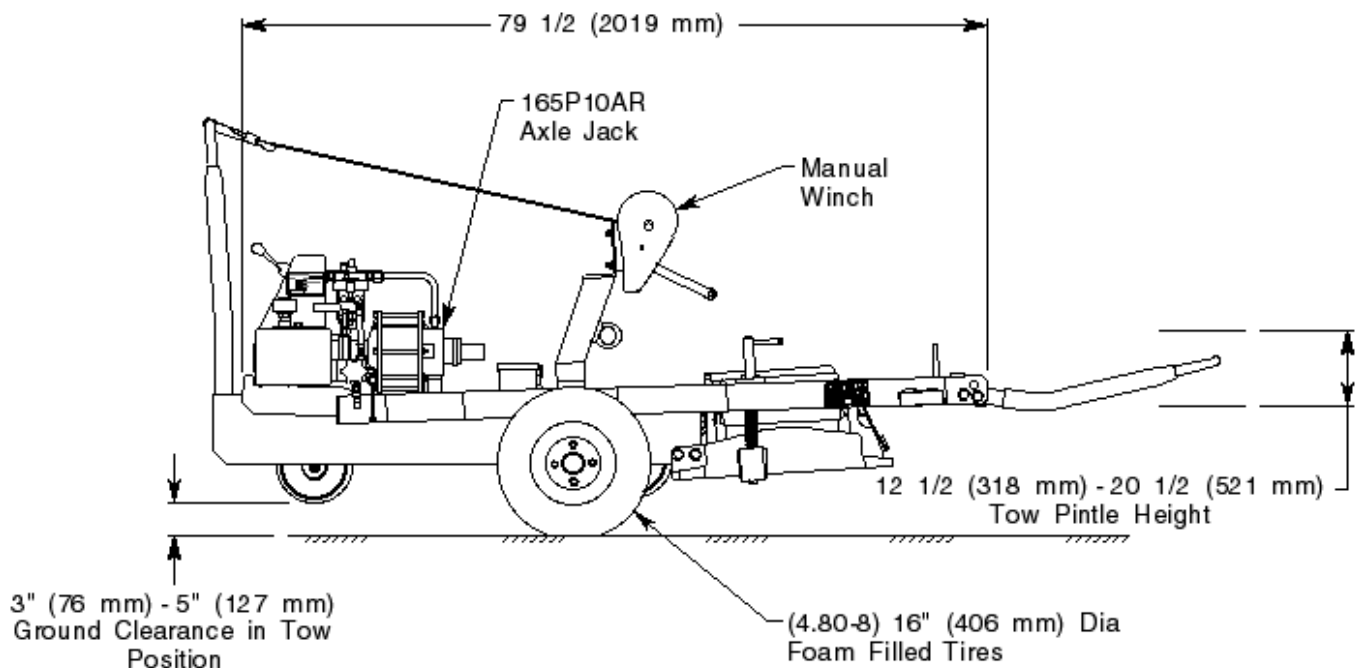
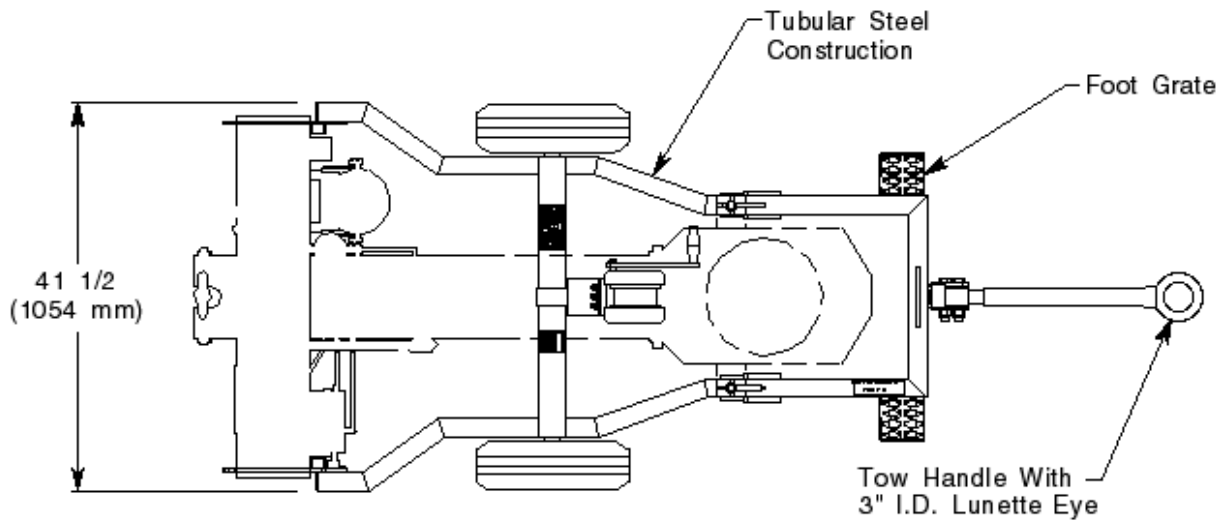

For more information contact: [sales@malabar.com](mailto:sales@malabar.com)

# Axle Jack Transporter

## Model 8867

### Specifications:

Unit Weight.....225 lbs (91 kg)  
 Unit Weight (with axle jack) ..... 1075 (476.3 kg)  
 Maximum Towing Speed ..... 20 mph (32.2 km/h)  
 Recommended Tow Vehicle Pintle Height ..... 12.5 inches (318 mm) to 20.5 inches (521 mm)

### Model 8867 Axle Jack Transporter Carries the Following Malabar Axle Jack Model:

**165P10AR**

### Optional Equipment Codes:

*(Specify with order)*

SPC: Special Paint Color

### Packaging Codes and Options:

*(Specify with order)*

-: Domestic Skid  
 EC: Export Crate (Additional Cost)

### **Shipping Data:**

NOTE: Unless otherwise specified, Model 8867 Axle Jack Transporter is shipped on a wood skid.

Packaging Code	Length inches (mm)	Width inches (mm)	Height inches (mm)	Weight lbs (kg)
-	82 (2083)	42 (1067)	42 (1067)	350 (159)
EC	83.5 (2121)	43.5 (1105)	44 (1118)	450 (204)