

MODEL 8867 AXLE JACK TRANSPORTER

TRANSPORTER INCLUDES:

- Manual Winch for loading/unloading axle jack
- 16" diameter foam filled tires
- Tow Handle with 3" Lunette Eye for towing
- All unpainted parts are plated to resist corrosion
- Skydrol Resistant Paint (safety yellow)
- 1 Year Warranty
- Shipping Skid

Model 8867 is built to withstand harsh environmental conditions, rugged use and to provide many years of continuous service. Our customers are guaranteed a quality product with each purchase and are assured of our continued product support whenever and wherever the need arises.

BENEFITS:

- Transporter virtually eliminates towing damage to axle jacks
- Foam filled tires are included which eliminate flats due to punctures and provides a cushioned ride
- Lightweight and rugged tubular frame construction
- Balanced design...only one persn is required to load and unload the axle jack

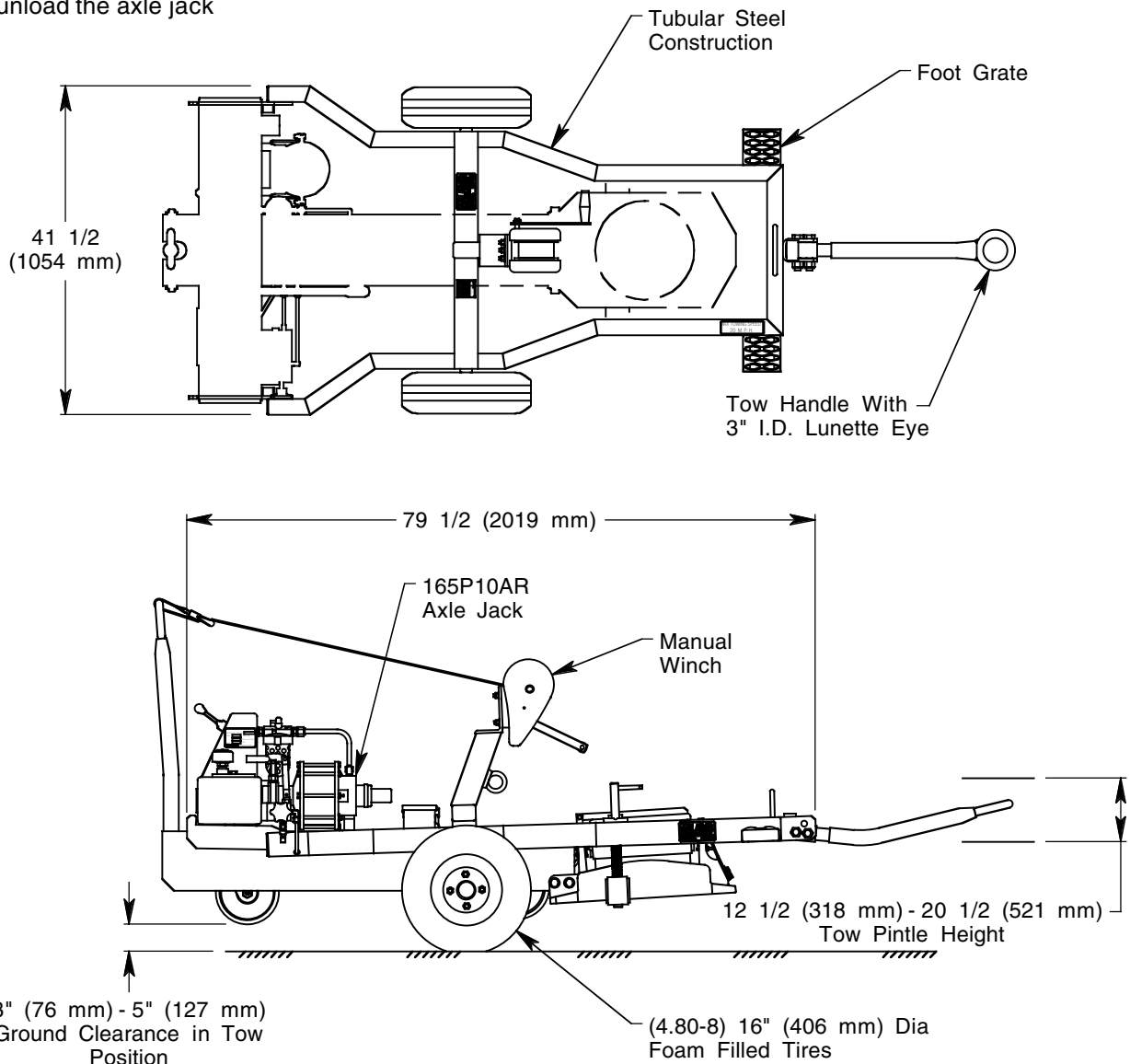

See Reverse Side for Specifications, Options, Aircraft Applications & Shipping Data

MODEL 8867 AXLE JACK TRANSPORTER

REDUCE AXLE JACK MAINTENANCE COST AND DOWNTIME.

Aircraft axle jacks are frequently subjected to significant wear and tear in today's fast-paced aircraft maintenance environment. Most axle jacks are built to withstand tow speeds up to 5 mph on smooth ramp surfaces. Excessive speed and/or uneven road or ramp surfaces accelerate wear and tear on the axle jack. Axle jack running gear components (casters, wheels, towbars and under carriage linkage), load gauges and jack cylinder bases are often damaged beyond economical repair even during the first year of operation. Labor costs and repair costs can easily approach several hundred dollars per year per jack.

The Model 8867 Transporter provides a simple yet effective solution for long distance, high speed (up to 20 mph) towing over rough and uneven surfaces.

SPECIFICATIONS

Unit Weight: 225 lbs (91 kg)
 Unit Weight (with axle jack): 1075 (476.3 kg)
 Maximum Towing Speed: 20 mph (32.2 km/h)
 Recommended Tow Vehicle Pintle Height: 12 1/2 (318 mm) to 20 1/2 (521 mm)
 Standard Finish: Yellow Skydrol resistant paint

MODEL 8867 AXLE JACK TRANSPORTER CARRIES THE FOLLOWING MALABAR AXLE JACK MODEL

165P10AR

OPTIONAL EQUIPMENT CODE: (Specify at time of order)

SPC: Special Paint Color (yellow is standard)

PACKAGING CODES & OPTIONS: (Specify at time of order)

— : Domestic Skid

EC: Export Crate (Additional Cost)

SHIPPING DATA

NOTE: Unless otherwise specified, Model 8867 axle jack transporter is shipped on a wood skid.

Packaging Code	Length inch (mm)	Width inch (mm)	Height inch (mm)	Weight lbs (kg)
—	82 (2083)	42 (1067)	42 (1067)	350 (159)
EC	83.5 (2121)	43.5 (1105)	44" (1118)	450 (204)