

2 Gallon Turbine Oil Dispenser

Model 250



The Model 250 Turbine Oil Dispenser is a 2 gallon fluid dispenser used to service various commercial aircraft engines, APUs, CSDs and IDGs. The hand pump dispenser consists of a reservoir, pump assembly, filter assembly and a fluid delivery hose.

Model 250 is built to withstand harsh environmental conditions and rugged use and to provide many years of continuous service. Our customers are guaranteed a quality product with each purchase and are assured of our continued product support whenever and wherever the need arises.

Standard Features:

- Durable, lightweight and portable 2 gallon capacity reservoir with integral carrying handle made from specially formulated "HS" crosslinked polyethylene material that is impervious to petroleum based fluids, hydraulic fluids, UV, solvents and cleaning solutions. "HS" units maintain a very high impact strength even at sub-zero temperatures and are available in several colorfast colors for easy identification of proper fluid type.
- Manual hand pump and inline filter to dispense clean filtered aircraft fluids into aircraft systems
- Large fillport
- 1 year standard warranty
- Fully enclosed shipping container

Optional Features:

- "HS" polyethylene colorfast colors or polished stainless steel fluid tanks
- 3 micron absolute filter or 1 micron waterstop filter
- Mechanical fluid totalizing meters
- Discharge pressure gauge
- Lockable fillport / inlet air dryer
- Various turbine oil fluid placards are available to ensure compliance with customer and aircraft manufacturer's line maintenance requirements
- Standard and special hose end fittings and couplings
- Fluid level gauge
- Accessories and repair kits

2-Gallon Turbine Oil Dispenser

Model 250

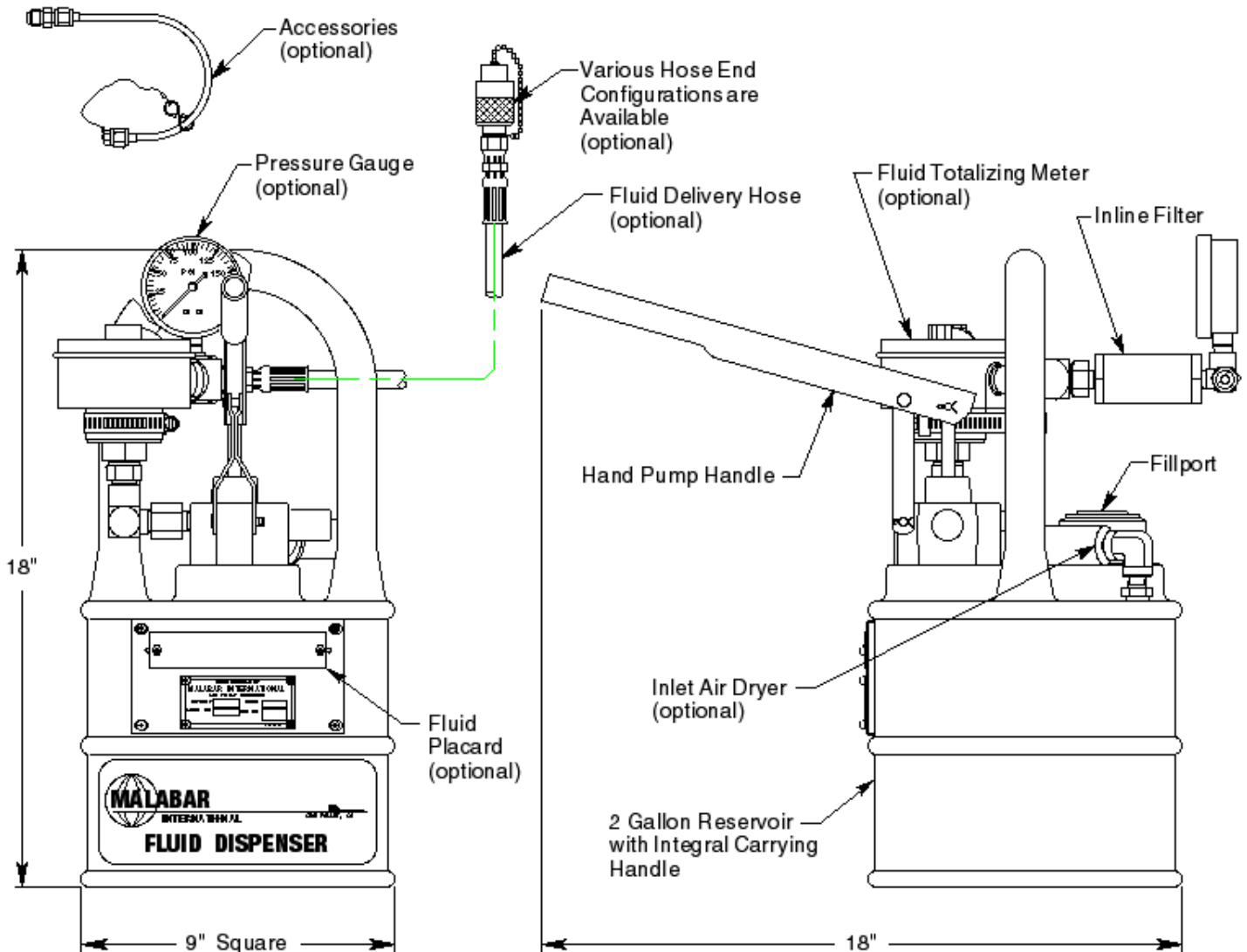

2-Gallon Turbine Oil Dispenser

Model 250

Specifications:

Fluid Type	Turbine Oil
Fluid Capacity	2 Gallon (7.6 liters)
Unit Displacement per Stroke.....	2.5 cu inches (41 cc)
Maximum Pump Outlet Pressure	100 psig (7 kg/sq cm)
Standard Hose Length.....	84 inches (2134 mm)
Standard Filter Rating.....	2-3 micron nominal
Net Weight "HS" Tank	12 lbs (5.4 kg)
Net Weight Stainless Steel Tank.....	18 lbs (8.2 kg)

Model 250 Typical Aircraft Applications:
Turbine oil for Aircraft Engines, APUs, CSDs and IDGs

Shipping Data:			
Length inches (mm)	Width inches (mm)	Height inches (mm)	Weight lbs (kg)
12 (305)	12 (305)	25 (635)	29 (13)

2-Gallon Turbine Oil Dispenser

Model 250

Ordering Code: 250G-01-1-0-1-01-0-0-0-A

FLUID TANK CONFIGURATION

- 250G:** Polyethylene, Green
- 250Y:** Polyethylene, Yellow
- 250B:** Polyethylene, Blue
- 250S:** Stainless Steel, Polished

FLUID DESIGNATION & PLACARD

- 00:** No Fluid Placard
- 01:** Turbo Oil 2380
- 02:** Engine / CSD Oil
- 03:** Turbine Oil
- 04:** Not for Main Engine Use, APU Type 1 Oil ETO 2389 (Use yellow tank)
- 05:** Mobil Jet II
- 06:** Esso 2380
- 07:** Exxon 2380
- 08:** MIL-L-7808
- 09:** Exxon 2380 Engine & Acc'y Oil
- 10:** Esso-TJ15 Turbo Compressor Oil
- 11:** Turbo Oil 2197 (use blue tank)
- 12:** Coolanol
- XX:** Other (contact Malabar Sales)

FILTER TYPE

- 1:** Standard Filter
- 2:** 3 Micron Absolute Filter
- 3:** 1 Micron Nominal Waterstop Filter

FLUID TOTALIZING METER

- 0:** No Fluid Meter
- 1:** Mechanical Meter, quarts & pints
- 2:** Mechanical Meter, liters
- 3:** Discontinued

DELIVERY HOSE

- 0:** No Delivery Hose
- 1:** Standard Hose, 84" (7 ft.) long
- 2:** Special Hose, 120" (10 ft.) long
- 3:** Special Hose, 240" (20 ft.) long
- 4:** Special Hose, 288" (24 ft.) long
- 5:** Special Hose, 48" (4 ft.) long
- X:** Other (contact Malabar Sales)

*ACCESSORIES (Optional)

- A:** Overflow Hose & Coupling for IDG/CSD Service (PF55951)
 - B:** Wetspline Adapter, CSD Only (PF53175)
 - C:** Overflow Hose & 90° elbow with 3/4-16 UNF 37° Female Swivel (PF56084)
 - D:** Repair Kit
 - XX:** Other (contact Malabar Sales)
- *Accessories are supplied as separate line items

FLUID LEVEL GAUGE

- 0:** No Gauge
- 1:** Level Gauge

FILL PORT / INLET AIR DRYER

- 0:** No Locking Port & No Air Dryer
- 1:** Locking Fillport Only
- 2:** Inlet Air Dryer & Non-vented Fillport

PRESSURE GAUGE

- 0:** No Pressure Gauge
- 1:** Standard Pressure Gauge
- 2:** Discontinued

HOSE END CONFIGURATION

- 00:** No Hose End Configuration
- 01:** 9/16-18 UNF 37° Female Swivel
- 02:** 3/16 Tube with 90° Bend & 37° Flared "B" Nut & Dust Plug (PF53339)
- 03:** 2506 Coupling (736-013) & Dust Plug
- 04:** 2506 Coupling (736-013), Dust Plug & Gravity Fill Adapter (PF55759)
- 05:** 2506 Coupling (736-013) with 45° Elbow (PF55817) & Dust Plug
- 06:** 7/16-20 UNF 37° Male with O-ring Seal (721-042)
- 07:** 1/4 Straight Tube & 37° Flared "B" Nut & Dust Plug (PF55805)
- 08:** 2505 Coupling (736-015) & Dust Plug
- 09:** VEAC4-4F (716-023) with Swage Sleeves & Dust Plug
- 10:** 1/4 'U' Tube with 37° Flared "B" Nut (PF53681), Dust Plug & Shutoff Valve
- 11:** VEAC4-4F (716-023) & Dust Plug with Adapter (PFCG10045-4)
- XX:** Other (contact Malabar Sales)