

165 Ton Floating Auto-Retract™ Axle Jack

Model 165P10AR



The Model 165P10AR Floating Auto-Retract Axle Jack is a 165 ton capacity, two stage hydraulic jack designed primarily for use in jacking the main and/or nose landing gear. The jack consists of a two stage cylinder assembly mounted on a spherical bearing (this bearing allows the jack ship adapter to follow the arc of the aircraft jack point, thus greatly reducing the stress on the jack's cylinder assembly as well as the aircraft axle and strut), base assembly, frame/reservoir assembly, valve block assembly, hand pump assembly, air pump kit, lubricator kit, control console and rain hat.

Model 165P10AR is built to withstand harsh environmental conditions, rugged use and to provide many years of continuous service. Our customers are guaranteed a quality product with each purchase and are assured of our continued product support whenever and wherever the need arises.

Standard Features:

- Patented floating cylinder assembly allows unit to track arc of landing gear jack point, eliminating excessive side loads on jack and landing gear thus providing safer operation and extending jack life
- Double acting auto-retract cylinder assembly incorporates a fluid bath for sealing surfaces to minimize corrosion and extend seal life. It also includes Skydrol resistant seals and bronze upper bearings for longer service life
- Auto-retract plungers remain fully retracted while jack is being towed or in storage to protect against corrosion, contaminants and accidental damage.
- Single valve control for simple and easy aircraft raising, lowering and auto-retract. Jack retracts to full retracted position automatically which provides for easy removal from under aircraft jack point after each operation
- Control console with all controls conveniently mounted for ease of operation.
- Hydraulic fuse at the cylinder assembly prevents lowering of load in the event of a hose failure
- Skydrol resistant paint (safety yellow)

Standard Features (cont.)

- 8 inch diameter heavy duty swivel casters and retractable front wheel with Skydrol resistant tread. The tow handle actuated front wheel provides improved ground clearance for towing
- Air operated hydraulic pump and air line lubricator
- Two manual hand pumps (one high pressure, low volume and one low pressure, high volume)
- Rain hat (covers cylinder assembly)
- Oil filter cap with filtered air vent and dipstick
- Hard chrome plated cylinder and plunger bores
- All unpainted parts are plated to resist corrosion
- Factory proof load @ 225 tons
- 1 year standard warranty
- Fully enclosed shipping container with skid

Optional Features:

- Load gauge for load indication (reads tons/psig)
- Ship adapter (3/4" female spherical radius) and storage box
- Lift ring kit (provides lift points to lift jack assembly)

165 Ton Floating Auto-Retract™ Axle Jack Model 165P10AR

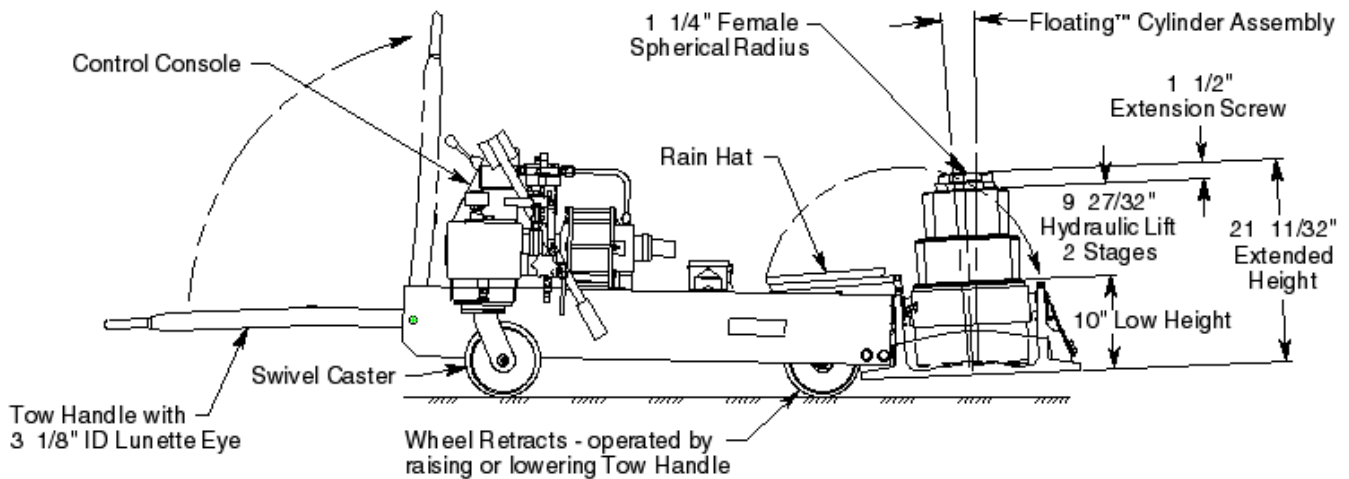
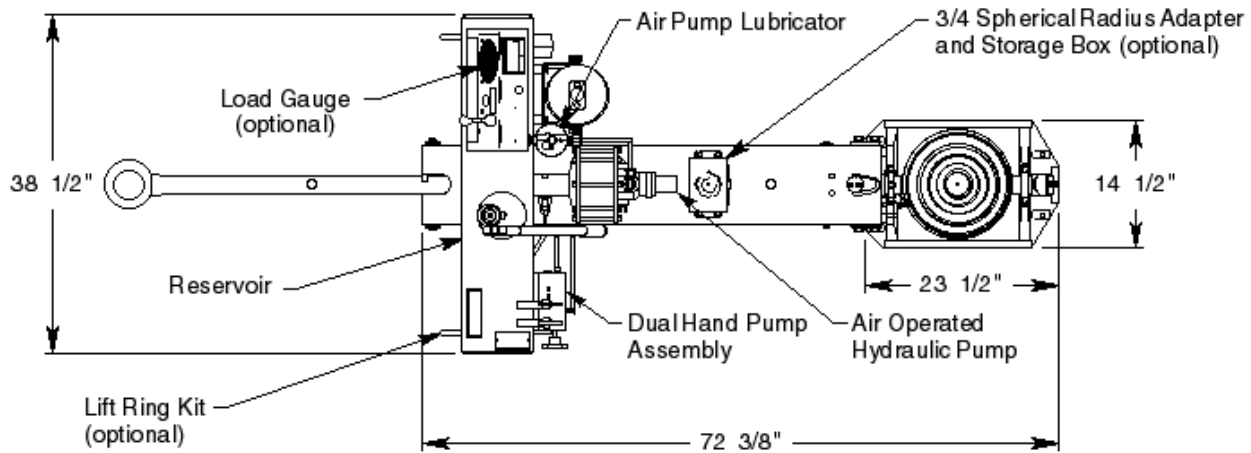

165 Ton Floating Auto-Retract™ Axle Jack

Model 165P10AR

Specifications:

Rated Capacity	165 tons (150.1 m. tons)
Low Height:	10.0 inches (254 mm)
Low Height with Optional Ship Adapter.....	11.25 inches (286 mm)
Hydraulic Lift	9.84 inches (250 mm)
Extension Screw	1.50 inches (38 mm)
Total Extended Height.....	21.34 inches (542 mm)
Total Extended Height with Optional Ship Adapter.....	22.6 inches (574 mm)
Base Width	14.5 inches (368.3 mm)
Cylinder Diameter	12.0 inches (304.8 mm)
Oil Pressure at Rated Capacity	7230 psig (508 kg/sq cm)
Primary Pop-off Valve set at:.....	181.5 tons (164.7 m. tons)
Secondary Pop-off Valve set at:.....	189.8 tons (172.2 m. tons)
Proof Load	225 tons (204.1 m. tons)
Floor Loading at Rated Capacity.....	1095 psi (77.0 kg/sq cm)
Reservoir Capacity	5.8 gallons (22.0 liters)
Hydraulic Fluid.....	MIL-PRF-5606 or equivalent
Maximum Towing Speed.....	5 mph (8 km/h)
Approximate Jack Net Weight.....	850 lbs (386 kg)

Model 165P10AR Typical Aircraft Applications:

Main Landing Gear	Nose Landing Gear
A350, A380-800 / -800F / -900, B787	A380-800 / -800F / -900

NOTE: Use optional 3/4 spherical radius cup for the following aircraft, main landing gear only:

A300, A310, A319, A320, A321, A330-300,
A340-200 / -300, A340-500 / -600, A350,
B767-400ER, B777-200 / -300 / -300ER, B787, MD11, DC10, L1011

Optional Equipment Codes:

(Specify with order)

- GA: Load Gauge
- LK: Lift Ring Kit (provides lift points to lift jack assembly)
- SA886627: Ship Adapter P/N 886627 (3/4" female spherical radius)

165 Ton Floating Auto-Retract™ Axle Jack

Model 165P10AR

Jack Accessories:

(Order separately)

- 165P10ARPK: Repair Kit
- 871420: Tire Slave Kit (to operate air-operated hydraulic pump from aircraft tire)
- 886700: Model 8867 165 Ton Axle Jack Transporter (trailer for long-distance, high-speed towing)

Shipping Data:

NOTE: Unless otherwise specified, Model 165P10AR jack is shipped on a wood skid and enclosed in a wood crate.

Length inches (mm)	Width inches (mm)	Height inches (mm)	Weight lbs (kg)
82 (2083)	45 (1143)	42 (1067)	1050 (476)