

# 50 Ton Auto-Retract™ Axle Jack

## Model 50P9AR



The Model 50P9AR Auto-Retract Axle Jack is a 50 ton capacity, two stage hydraulic jack designed primarily for use in jacking the main and/or nose landing gear of various aircraft. The jack consists of a two stage cylinder assembly, frame/reservoir assembly, valve block assembly, hand pump assembly and control console.

Model 50P9AR is built to withstand harsh environmental conditions, rugged use and to provide many years of continuous service. Our customers are guaranteed a quality product with each purchase and are assured of our continued product support whenever and wherever the need arises.

### Standard features:

- Double acting auto-retract™ cylinder assembly incorporates a fluid bath for sealing surfaces to minimize corrosion and extend seal life. It also includes skydrol resistant seals and bronze upper bearings for longer service life
- Auto-retract™ plungers remain fully retracted while jack is being towed or in storage to protect against corrosion, contaminants and accidental damage
- Single valve control for simple and easy aircraft raising, lowering and auto-retract™. Jack retracts to full retracted position automatically which provides for easy removal from under aircraft jack point after each operation
- Control console with all controls conveniently mounted for ease of operation
- 8" diameter heavy duty swivel casters and retractable front wheel with skydrol resistant tread. The tow handle actuated front wheel provides improved ground clearance for towing

### Standard features (cont.)

- Hydraulic fuse at the cylinder assembly prevents lowering of load in the event of a fluid line failure
- Two manual hand pumps (one high pressure, low volume and one low pressure, high volume)
- Oil filter cap with filtered air vent and dipstick
- Hard chrome plated cylinder and plunger bores
- All unpainted parts are plated to resist corrosion
- Skydrol resistant paint (safety yellow)
- Factory proof load @ 150% of rated capacity
- 1 year warranty
- Fully enclosed shipping container with skid

### Optional features:

- Air operated hydraulic pump
- Load gauge for load indication (reads tons/psig)
- Air line lubricator (for air operated hydraulic pump)
- Heavy duty ship adapter
- Rain hat (covers cylinder assembly)

# 50 Ton Auto-Retract™ Axle Jack

## Model 50P9AR

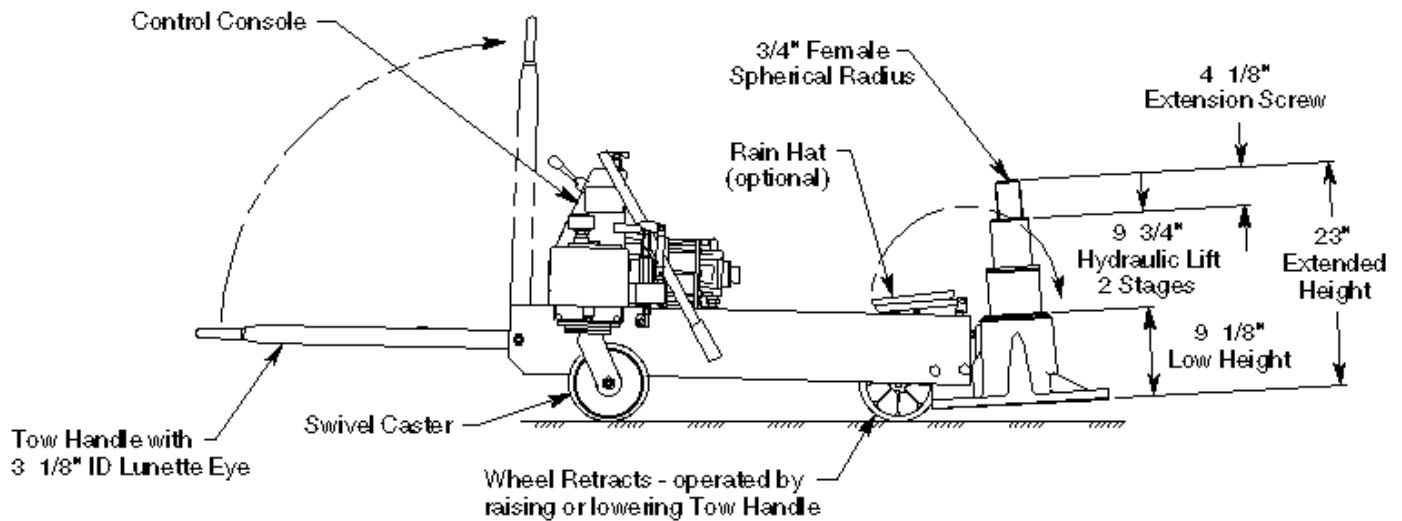
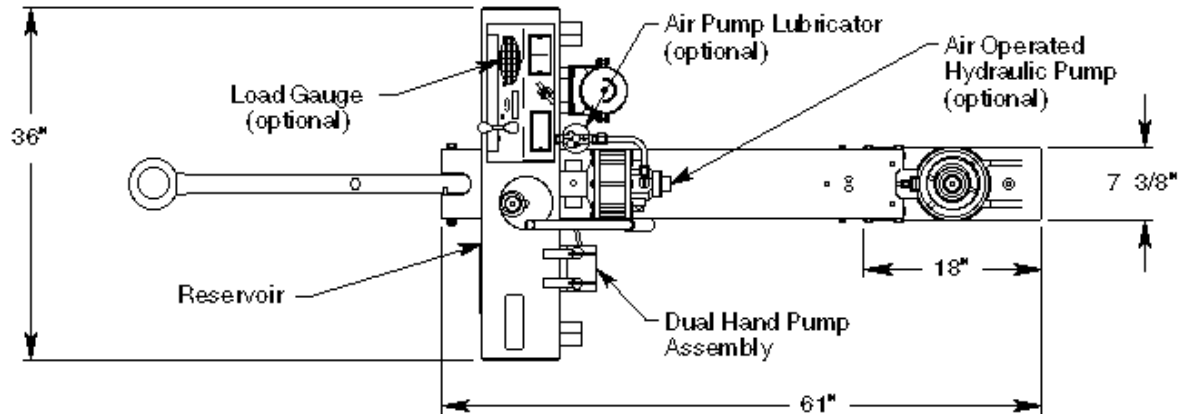

# 50 Ton Auto-Retract™ Axle Jack

## Model 50P9AR

### Specifications:

|                                      |                            |
|--------------------------------------|----------------------------|
| Rated Capacity .....                 | 50 tons (45.4 m. tons)     |
| Side Load.....                       | 15% of vertical load       |
| Low Height:.....                     | 9.13 inches (232 mm)       |
| Hydraulic Lift.....                  | 9.75 inches (248 mm)       |
| Extension Screw.....                 | 4.13 inches (105 mm)       |
| Total Extended Height.....           | 23 inches (584 mm)         |
| Base Width .....                     | 7.38 inches (187 mm)       |
| Cylinder Diameter.....               | 7.38 inches (187 mm)       |
| Oil Pressure at Rated Capacity.....  | 6660 psig (468 kg/sq cm)   |
| Safety Pop-off Valve set at:.....    | 53 tons (48.1 m. tons)     |
| Proof Load .....                     | 75 tons (68.0 m. tons)     |
| Floor Loading at Rated Capacity..... | 830 psi (58 kg/sq cm)      |
| Reservoir Capacity .....             | 5.5 gallons (20.8 liters)  |
| Hydraulic Fluid.....                 | MIL-PRF-5606 or equivalent |
| Maximum Towing Speed.....            | 5 mph (8 km/h)             |
| Approximate Jack Net Weight.....     | 480 lbs. (218 kg)          |

| <b>Model 50P9AR Typical Aircraft Applications:</b>                     |   |
|--|---|
| <b>Main Landing Gear</b>   | <b>Nose Landing Gear</b>                            |
| A319, A320, A321, B717, B727, B737<br>B757, DC8, DC9, F100, MD80, MD90 | A319, A320, A321, B727,<br>B737-600 THRU -900, B757 |

### Optional Equipment Codes:

*(Specify with order)*

- AP: Air Operated Hydraulic Pump
- GA: Load Gauge
- LU: Lubricator (requires air operated hydraulic pump)
- RH: Rain Hat
- SA: Ship Adapter, Heavy Duty
- SPC: Special Paint Color (yellow is standard)

# 50 Ton Auto-Retract™ Axle Jack

## Model 50P9AR

### Jack Accessories:

*(Order Separately)*

- 50P9ARPK: Repair Kit
- 871420: Tire Slave Kit (to operate air operated hydraulic pump from aircraft tire)
- 880470: Lift Ring Kit (provides three lift points to lift jack assembly)
- 881700: Model 8817 Universal Axle Jack Transporter (trailer for long distance, high speed towing)
- 873828: Extender Kit (for B747-400ER NLG)

### Shipping Data:

NOTE: Unless otherwise specified, Model 50P9AR jack is shipped on a wood skid with an enclosed cover. Refer to Malabar Axle Jack Shipping Supplement for additional packaging information.

| Length<br>inches (mm) | Width<br>inches (mm) | Height<br>inches (mm) | Weight<br>lbs (kg) |
|-----------------------|----------------------|-----------------------|--------------------|
| 70 (1778)             | 45 (1143)            | 34 (864)              | 540 (245)          |