

65 Ton Floating™ Beam Assembly

Model 65L4.5



The Model 65L4.5 65 Ton Floating Beam Assembly is used for emergency dual flats or on rim conditions. The beam includes the patented Floating™ beam assembly, which enables emergency dual flat or on rim jacking in conjunction with a Malabar 65P10 or 65P10AR floating Auto-Retract™ Axle Jack.

Model 65L4.5 is suitable for most Airbus and Boeing aircraft. This unit includes a cantilever lift beam to access the axle jack point in case of emergency landing gear flats or on rim conditions.

Model 65L4.5 is built to withstand harsh environmental conditions and rugged use, and to provide many years of continuous service. Our customers are guaranteed a quality product with each purchase and are assured of our continued product support whenever and wherever the need arises.

Standard Features:

- Patented Floating™ Beam Assembly for emergency dual flat or on rims jacking in conjunction with a model 65P10 or 65P10AR Floating Auto-Retract™ Axle Jack
- 12 inch diameter heavy duty wheels with Skydrol resistant tread
- Tow handle with 3 inch lunette eye for towing
- All unpainted parts are plated to resist corrosion
- Skydrol resistant paint (safety yellow)
- Factory proof load @ 150% of rated capacity
- 1 year standard warranty
- Shipping skid

Optional Features:

- 65P10AR 65 Ton Axle Jack (provides lift for beam)
- Customer specified paint color
- Export crate

65 Ton Floating™ Beam Assembly

Model 65L4.5

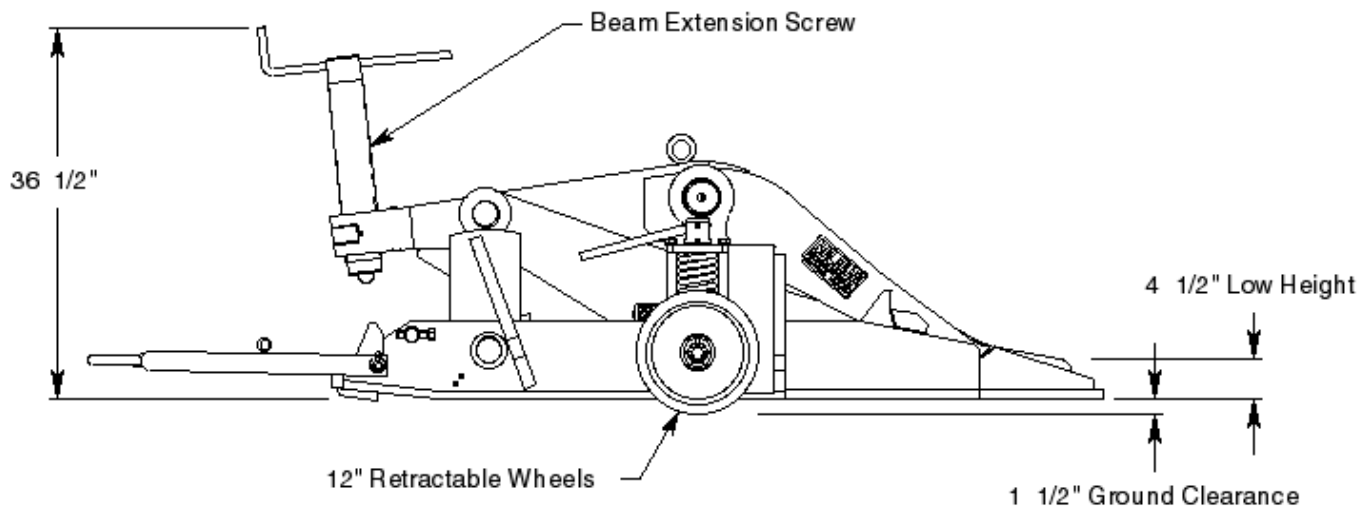
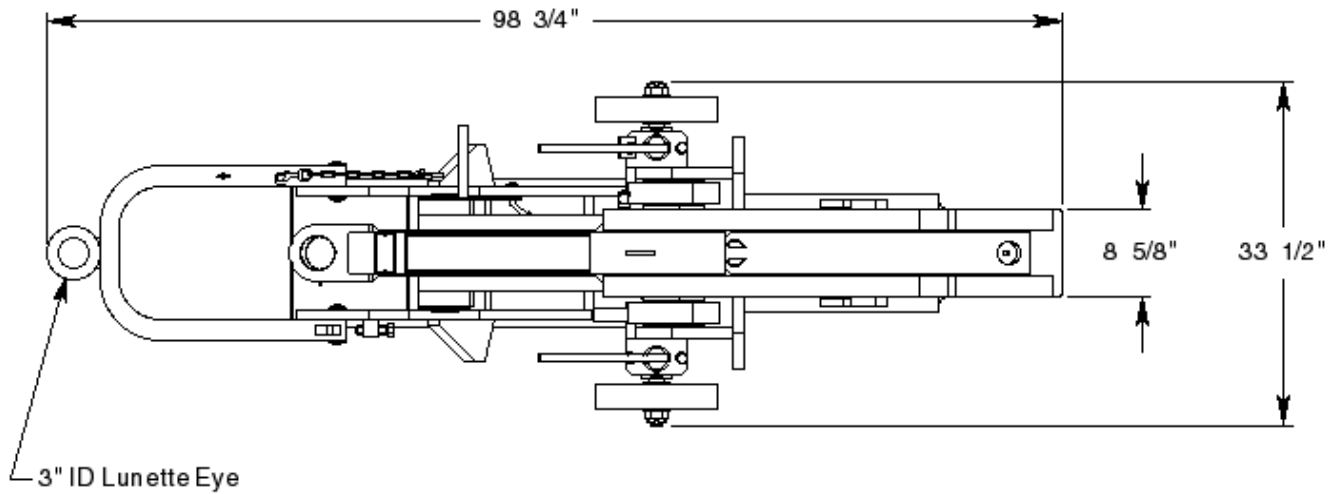

65 Ton Floating™ Beam Assembly

Model 65L4.5

Specifications:

Rated Capacity	65 tons (59.0 m. tons)
Low Height with Standard Adapter.....	4.5 inches (114 mm)
Low Height with 747 NLG Adapter.....	8.5 inches (216 mm)
Lift (Provided by Malabar Jack/Beam Extension Screw)	17.5 inches (445 mm)
Total Extended Height with Standard Adapter	22 inches (559 mm)
Total Extended Height with 747 NLG Adapter	26 inches (660 mm)
Base Width (Under Jack Point)	8.6 inches (220 mm)
Beam Width (Under Jack Point).....	4.0 inches (102 mm)
Proof Load	97.5 tons (88.5 m. tons)
Maximum Towing Speed.....	5 mph (8 km/h)
Approximate Beam Net Weight.....	2400 lbs (1089 kg)

Model 65L4.5 Typical Aircraft Applications:

Main Landing Gear	Nose Landing Gear
A300, A310, A319, A320, A321, A330, B707, B720, B727, B737, B747, B747-8, B757, B767, B787, DC10, MD11	A300, A310, A330, B747, B747-8, B767, B787

Optional Equipment Codes:

(Specify with order)

SPC: Special Paint Color (yellow is standard)

Beam Accessories:

(Order separately)

65P10AR: 65 Ton Axle Jack (provides lift for beam)

Packaging Codes & Options

(Specify with order)

- : Domestic Skid
- EC: Export Crate (Additional Cost)

65 Ton Floating™ Beam Assembly

Model 65L4.5

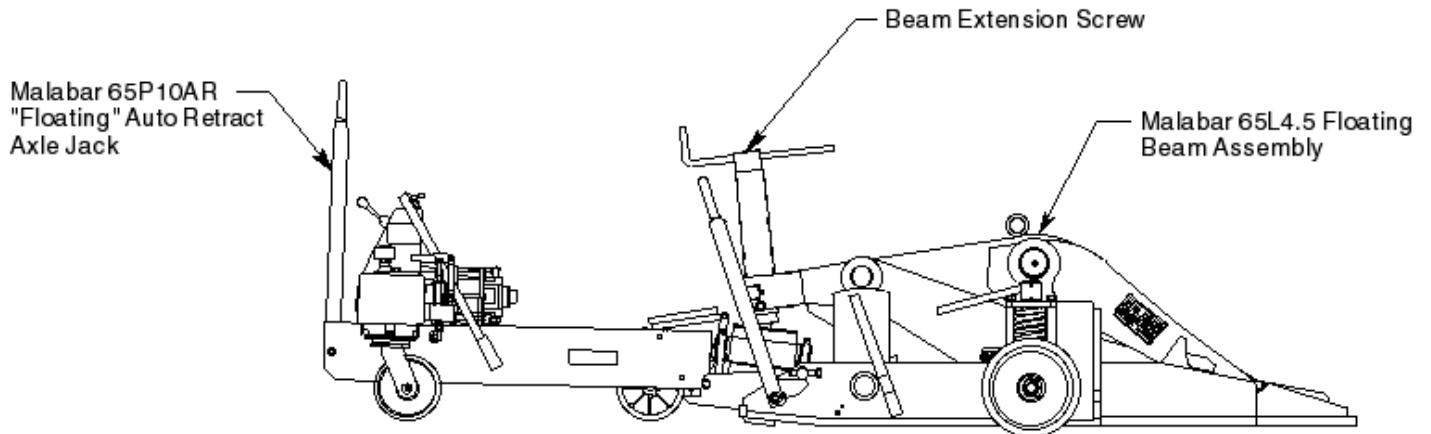

Shipping Data:

NOTE: Unless otherwise specified, Model 65L4.5 beam is shipped on a wood skid.

Packaging Code	Length inches (mm)	Width inches (mm)	Height inches (mm)	Weight lbs (kg)
—	82 (2083)	40 (1016)	40 (1016)	2500 (1134)
EC	84 (2134)	45 (1143)	43 (1092)	2800 (1270)