

# 5 Point Aircraft Weigh System

## Model 8689A



The Model 8689A is designed to weigh all wide and narrow body aircraft and does not include an electronic load cell system. This system is compatible with various Intercomp and Revere load cell systems. Contact Malabar for complete information.

Model 8689A is built to withstand harsh environmental conditions, rugged use and to provide many years of continuous service. Our customers are guaranteed a quality product with each purchase and are assured of our continued product support whenever and wherever the need arises.

### Standard Features:

- Rugged power cart with high capacity air operated hydraulic pump and vacuum retract system
- Weigh jack loading ramp, 10 ga steel work top and four wheel running gear with friction brakes
- Weigh jack and electronic weigh kit storage areas
- Hydraulic reservoir with fluid level sight and manifold with release valve and shutoff valves
- Two hand pumps (high and low pressure)
- Conveniently located single valve control for raising and lowering weigh jacks
- Five hydraulic hoses on hose racks with mating quick disconnect couplings for 50 ton weigh jacks
- Five 50 ton capacity weigh jacks with load cell sockets, extension screws, dual wheels, high pressure shutoff valves and quick disconnect nipples
- 10 ton capacity weigh jack with load cell socket, extension screw, integral hand pump, relief valve and hydraulic reservoir

### Standard Features (Cont'd)

- All weigh jacks include hard chrome plated cylinder and plunger bores, plated extension screws and are proof load tested to 150% of their rates capacity
- Adapter for B747 nose landing gear
- All unpainted parts are plated to resist corrosion
- Skydrol resistant paint (safety yellow)
- Shipment on domestic skid
- 1 year standard warranty

### Optional Features:

- Customer specified paint color
- Export crating

# 5 Point Aircraft Weigh System

## Model 8689A

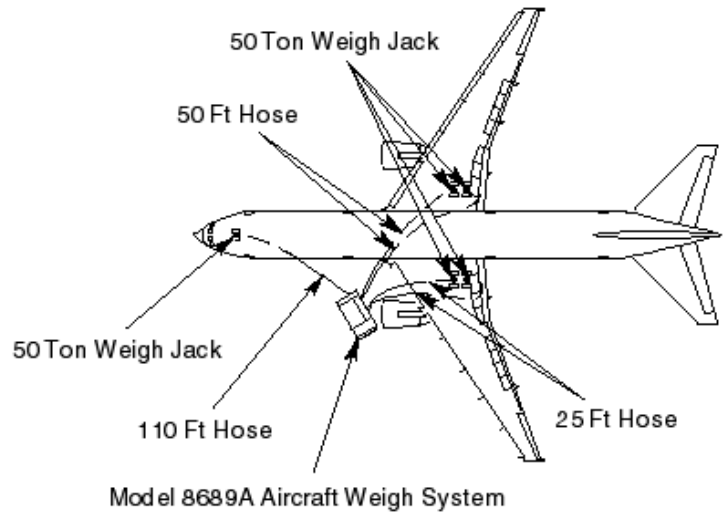
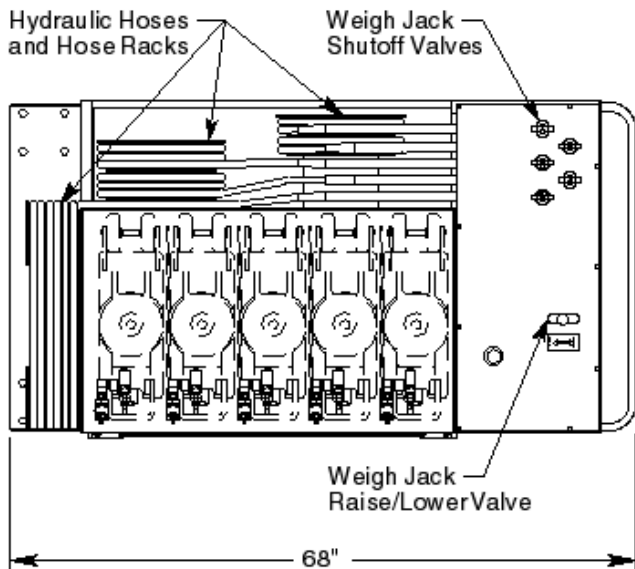

Typical Wide Body Aircraft Weigh System Application

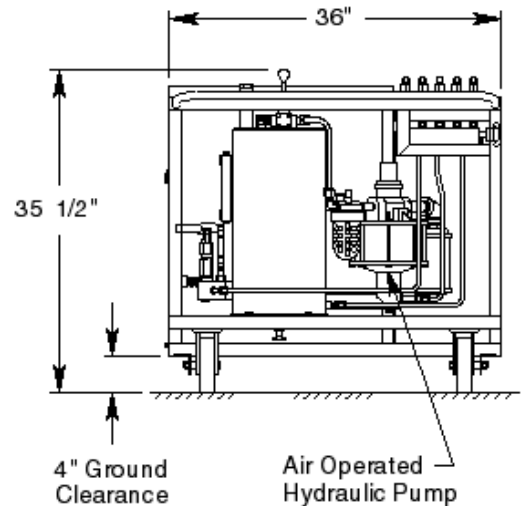
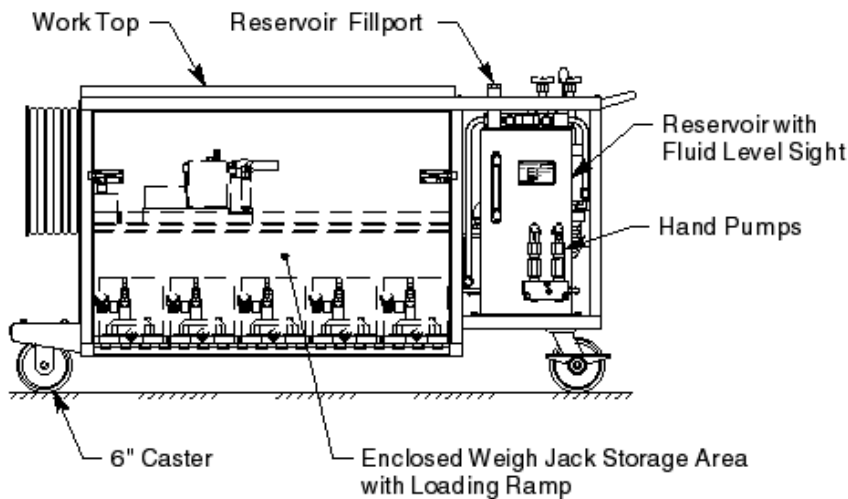

# 5 Point Aircraft Weigh System

## Model 8689A

### Specifications:

#### WEIGH CART

Oil Pressure at 50 Ton Weigh Jack Rated Capacity .....	5940 psig (418 kg/sq cm)
Reservoir Capacity.....	5.5 gallons (20.8 liters)
Hydraulic Fluid .....	MIL-PRF-5606 or equivalent
Hydraulic Hose (2 each) .....	25 ft (7620 mm)
Hydraulic Hose (2 each) .....	50 ft (15240 mm)
Hydraulic Hose (1 each) .....	110 ft (33528 mm)

#### 50 TON WEIGH JACK (5 each)

Rated Capacity.....	50 tons (45.4 m. tons)
Low Height Without Load Cell .....	7.13 inches (181 mm)
Hydraulic Lift .....	7.81 inches (198 mm)
Extension Screw .....	3 inches (76 mm)
Total Extended Height Without Load Cell.....	17.9 inches (456 mm)
Oil Pressure at Rated Capacity .....	5940 psig (418 kg/sq cm)
Proof Load.....	75 tons (68.0 m. tons)
Safety Pop-off Valve Set At .....	52.5 tons (47.6 m. tons)
Floor Loading at Rated Capacity .....	933 psi (65.6 kg/sq cm)
Approximate Jack Net Weight .....	135 lbs (61 kg)

#### 10 TON WEIGH JACK

Rated Capacity.....	10 tons (9.1 m. tons)
Low Height Without Load Cell .....	4 inches (102 mm)
Hydraulic Lift .....	3.75 inches (95 mm)
Extension Screw .....	1.5 inches (38 mm)
Total Extended Height Without Load Cell.....	9.25 inches (235 mm)
Oil Pressure at Rated Capacity .....	5140 psig (361 kg/sq cm)
Safety Pop-off Valve Set At .....	11 tons (10.0 m. tons)
Proof Load.....	15 tons (13.6 m. tons)
Reservoir Capacity.....	0.4 gallons (1.5 liters)
Floor Loading at Rated Capacity .....	351 psi (24.7 kg/sq cm)
Hydraulic Fluid .....	MIL-PRF-5606 or equivalent
Approximate Jack Net Weight .....	33 lbs (15 kg)

# 5 Point Aircraft Weigh System

## Model 8689A

### Model 8689A Typical Aircraft Applications

Wide Body and Narrow Body Aircraft

### Optional Equipment Codes:

*(Specify with order)*

SPC: Special Paint Color

### Jack Accessory Codes:

*(Specify with order)*

868712: Adapter (Revere 50k nose load cell)

868713: Adapter (Intercomp 50k nose load cell)

### Packaging Codes and Options:

*(Specify with order)*

-: Domestic Skid

EC: Export Crate (Additional Cost)

### Shipping Data:

NOTE: Unless otherwise specified, Model 8689A is shipped on a wood skid.

Packaging Code	Length inches (mm)	Width inches (mm)	Height inches (mm)	Weight lbs (kg)
-	72 (1829)	40 (1016)	41 (1041)	1100 (499)
EC	75 (1905)	45 (1143)	44 (1118)	1300 (590)