

MODEL 8689A 5-POINT AIRCRAFT WEIGH SYSTEM

WEIGH SYSTEM INCLUDES:

- Rugged Power Cart with high capacity Air Operated Hydraulic Pump and Vacuum Retract System
- Weigh jack Loading Ramp, 10 ga steel Work Top and four wheel Running Gear with Friction Brakes
- Weigh jack and electronic weigh kit Storage Areas
- Hydraulic Reservoir with fluid level sight and Manifold with Release Valve and Shutoff Valves
- Two Hand Pumps (high and low pressure)
- Conveniently located Single Valve Control for raising and lowering weigh jacks
- Five Hydraulic Hoses on hose racks with mating quick disconnect couplings for 50 ton weigh jacks
- Five 50 Ton capacity Weigh Jacks with load cell sockets, extension screws, dual wheels, high pressure shutoff valves and quick disconnect nipples
- 10 Ton capacity Weigh Jack with load cell socket, extension screw, integral hand pump, relief valve and hydraulic reservoir

- All weigh jacks include Hard Chrome Plated cylinder and plunger bores, Plated extension screws and are Proof Load Tested to 150% of their rated capacity
- Adapter for B747 nose landing gear
- All unpainted parts are plated to resist corrosion
- Skydrol Resistant Paint (safety yellow)
- Shipping Skid

NOTE: System is compatible with various electronic weigh kits. Contact Malabar for complete information

Model 8689A is built to withstand harsh environmental conditions, rugged use and to provide many years of continuous service. Our customers are guaranteed a quality product with each purchase and are assured of our continued product support whenever and wherever the need arises.

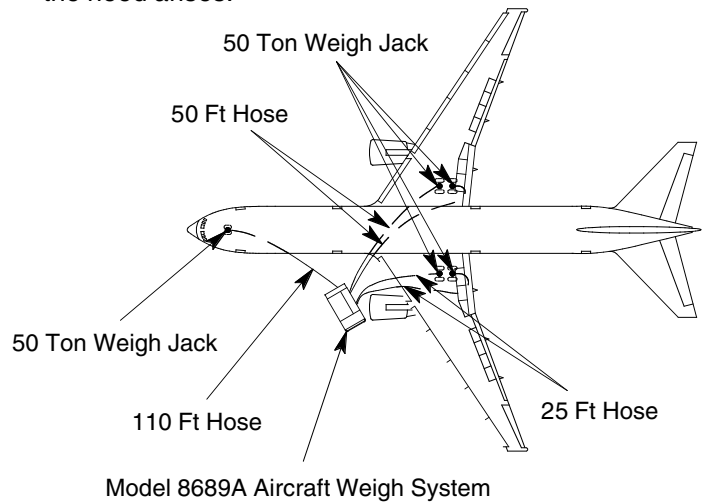
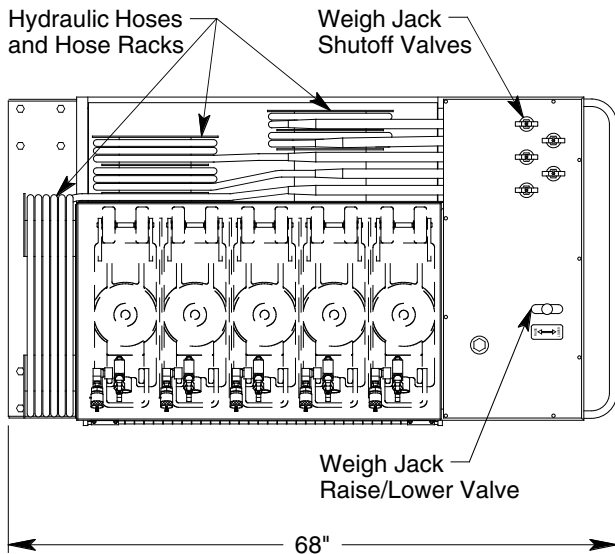

Typical Wide Body Aircraft Weigh System Application

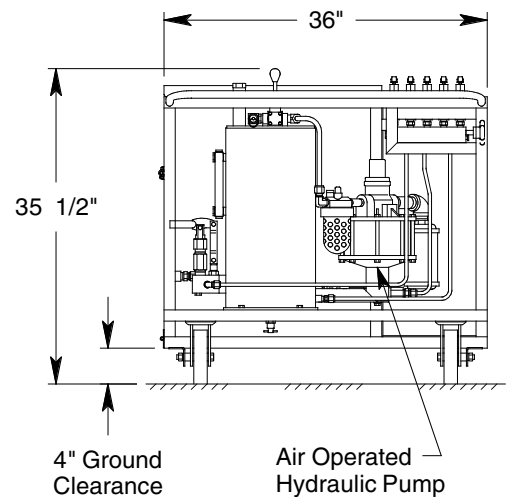
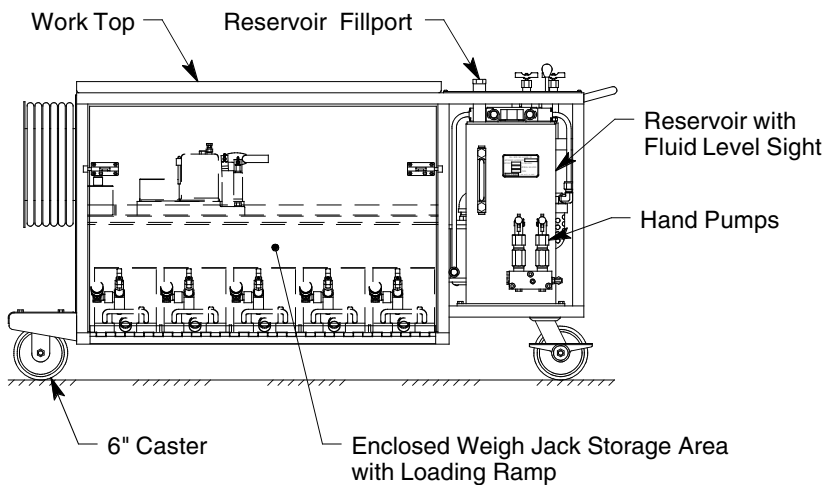

See Reverse Side for Specifications, Options & Shipping Data

MODEL 8689A 5-POINT AIRCRAFT WEIGH SYSTEM

SPECIFICATIONS

WEIGH CART

Oil Pressure at 50 Ton Weigh Jack Rated Capacity: 5940 psig (418 kg/sq cm)
 Reservoir Capacity: 5.5 gallons (20.8 liters)
 Hydraulic Fluid: MIL-H-5606 or equivalent
 Hydraulic Hose (2 each): 25 ft (7620 mm)
 Hydraulic Hose (2 each): 50 ft (15240 mm)
 Hydraulic Hose (1 each): 110 ft (33528 mm)

50 TON WEIGH JACK (5 EACH)

Rated Capacity: 50 tons (45.4 m. tons)
 Low Height without load cell: 7.13 inches (181 mm)
 Hydraulic Lift: 7.81 inches (198 mm)
 Extension Screw: 3 inches (76 mm)
 Total Extended Height without load cell: 17.9 inches (456 mm)
 Oil Pressure at Rated Capacity: 5940 psig (418 kg/sq cm)
 Proof Load: 75 tons (68.0 m. tons)
 Safety Pop-off Valve set at: 52.5 tons (47.6 m. tons)
 Floor Loading at Rated Capacity: 933 psi (65.6 kg/sq cm)
 Approximate Jack Net Weight: 135 lbs (61 kg)

10 TON WEIGH JACK

Rated Capacity: 10 tons (9.1 m. tons)
 Low Height without load cell: 4 inches (102 mm)
 Hydraulic Lift: 3.75 inches (95 mm)
 Extension Screw: 1.5 inches (38 mm)
 Total Extended Height without load cell: 9.25 inches (235 mm)
 Oil Pressure at Rated Capacity: 5140 psig (361 kg/sq cm)
 Safety Pop-off Valve set at: 11 tons (10.0 m. tons)
 Proof Load: 15 tons (13.6 m. tons)
 Reservoir Capacity: 0.4 gallons (1.5 liters)
 Floor Loading at Rated Capacity: 351 psi (24.7 kg/sq cm)
 Hydraulic Fluid: MIL-H-5606 or equivalent
 Approximate Jack Net Weight: 33 lbs (15 kg)

MODEL 8689A TYPICAL AIRCRAFT APPLICATIONS

Wide Body and Narrow Body Aircraft

JACK ACCESSORIES: (Order separately)

868712: Adapter (Revere 50k nose load cell)
 868713: Adapter (Intercomp 50k nose load cell)

PACKAGING CODES & OPTIONS: (Specify at time of order)

— : Domestic Skid
 EC: Export Crate (Additional Cost)

SHIPPING DATA

NOTE: Unless otherwise specified, Model 8689A is shipped on a wood skid.

Packaging Code	Length inch (mm)	Width inch (mm)	Height inch (mm)	Weight lbs (kg)
—	72 (1829)	40 (1016)	41 (1041)	1100 (499)
EC	75 (1905)	45 (1143)	44 (1118)	1300 (590)