

# 35-Ton “Fly-Away” Axle Jack

## Model 8782

The Model 8782 “Fly-Away” Axle Jack is a 35 ton capacity, three stage hydraulic jack designed primarily for use in jacking main and/or nose landing gear of various aircraft. The jack consists of a three stage cylinder assembly, air operated hydraulic pump with air relief valve and valve block and hand pump assembly.

Model 8782 is built to withstand harsh environmental conditions, rugged use and to provide many years of continuous service. Our customers are guaranteed a quality product with each purchase and are assured of our continued product support whenever and wherever the need arises.

### Standard Features:

- Hard chrome plated cylinder and plunger bores
- Extension screw and hand pump parts are plated to resist corrosion
- Two manual hand pumps (one high pressure, low volume and one low pressure, high volume)
- Air operated hydraulic pump for power operation
- Skydrol resistant paint (safety yellow)
- Factory proof load @ 150% of rated capacity
- 1 year standard warranty
- Fully enclosed shipping container

### Optional Features:

- Permanent shipping and storage enclosure
- Customer specified paint color
- Repair kit

# 35-Ton “Fly-Away” Axle Jack

## Model 8782

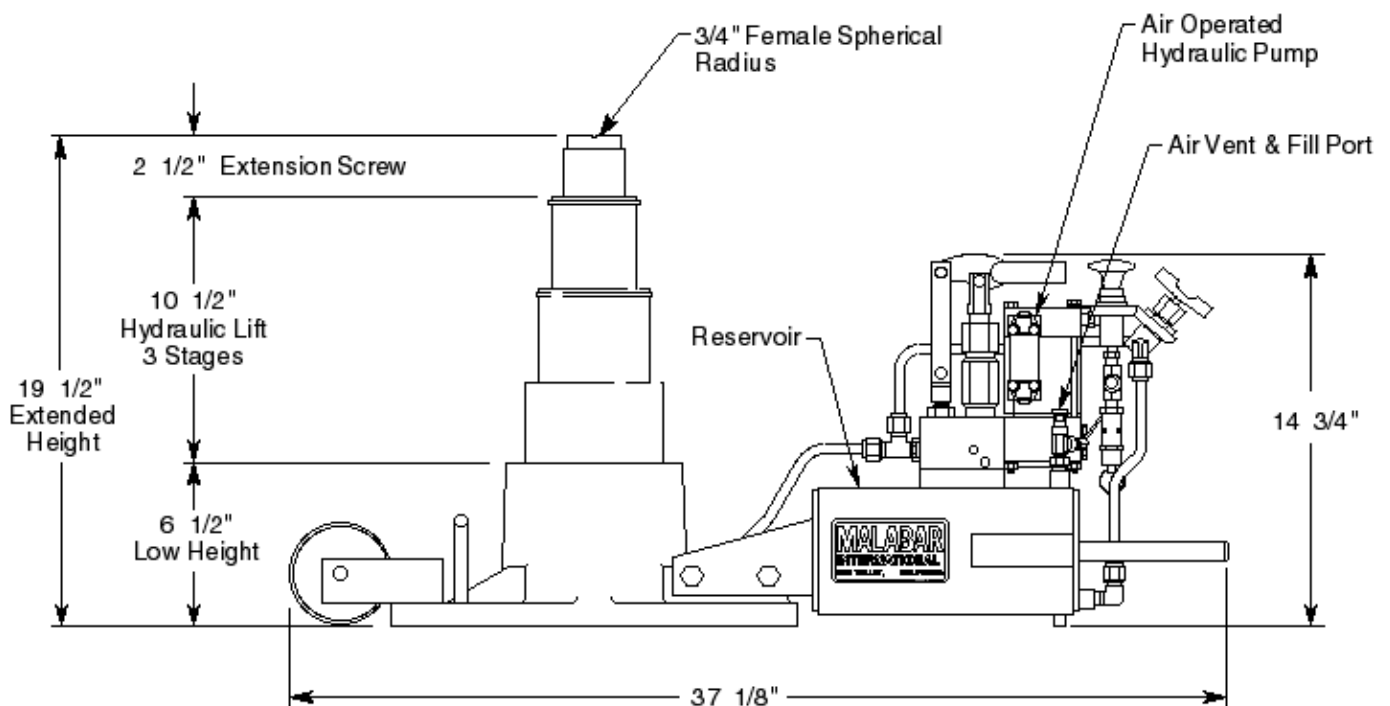
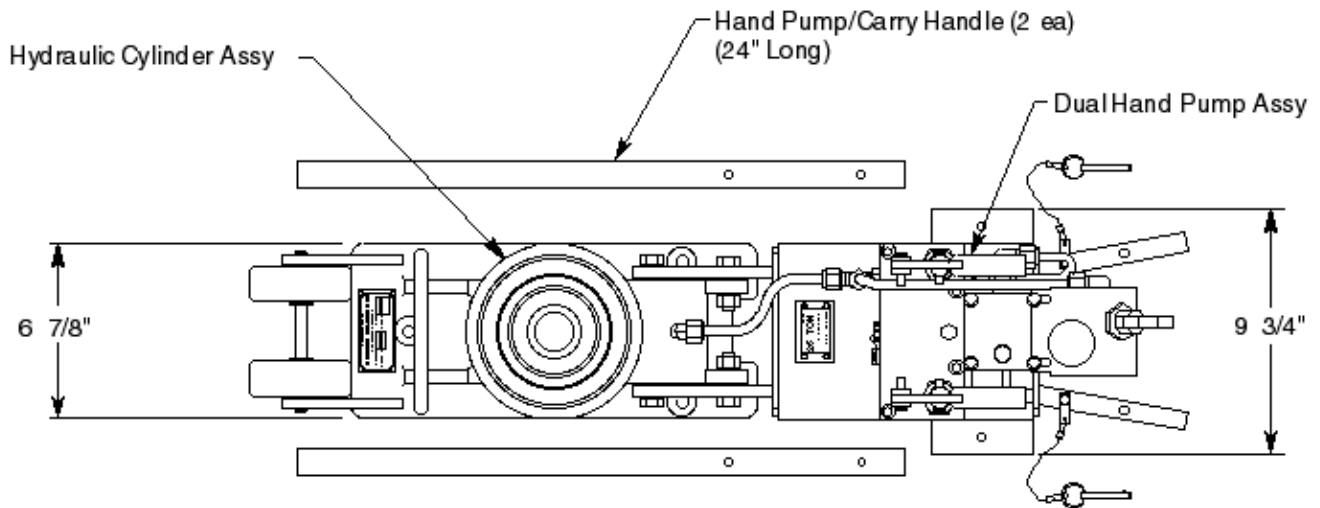

For more information contact: [sales@malabar.com](mailto:sales@malabar.com)

# 35-Ton “Fly-Away” Axle Jack

## Model 8782

### Specifications:

Rated Capacity.....	35 tons (31.8 m. tons)
Side Load .....	15% of vertical load
Low Height .....	6.5 inches (165 mm)
Hydraulic Lift .....	10.5 inches (267 mm)
Extension Screw .....	2.5 inches (64 mm)
Total Extended Height .....	19.5 inches (495 mm)
Oil Pressure at Rated Capacity .....	6760 psig (475 kg/sq cm)
Safety Pop-off Valve set at .....	38.5 tons (34.9 m. tons)
Proof Load.....	52.5 tons (47.6 m. tons)
Reservoir Capacity.....	1.1 gallons (4.2 liters)
Hydraulic Fluid .....	MIL-PRF-5606 or equivalent
Approximate Jack Net Weight .....	155 lbs (70 kg)
Total Handle Load (Wheeling) .....	40 lbs (18kg)

### Model 8782 Typical Aircraft Applications:

Main Landing Gear	Nose Landing Gear
880, 890, A318, A319, B717, B737, B757, BAC 1-11, BAE146, C130, DC9, F28, F100, HS125, MD80, MD90	A318, A319, A320, A321, B737, B757, C130

### Optional Equipment Codes:

*(Specify with order)*

- SPC: Special Paint Color (yellow is standard)
- 8782PK: Repair Kit

### Jack Accessories:

*(Specify with order)*

- 499-172: Permanent Shipping and Storage Enclosure

### Shipping Data:

NOTE: Model 8782 jack is shipped in a fully enclosed shipping container.

Length inches (mm)	Width inches (mm)	Height inches (mm)	Weight lbs (kg)
42 (1067)	15 (381)	22 (559)	220 (100)