

DWGNO. SK8838		SH 1	REV 1
REVISIONS			
ZONE	REV	DESCRIPTION	DATE BY APPROVED

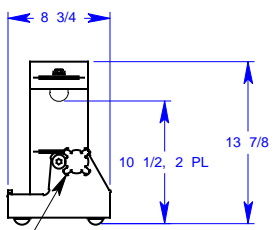

VERTICAL POSITION  
HAND KNOB LOCK  
ASSEMBLY

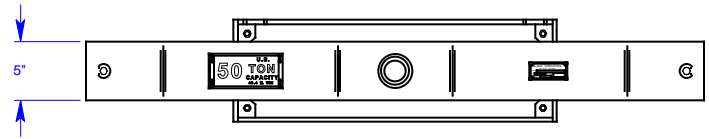
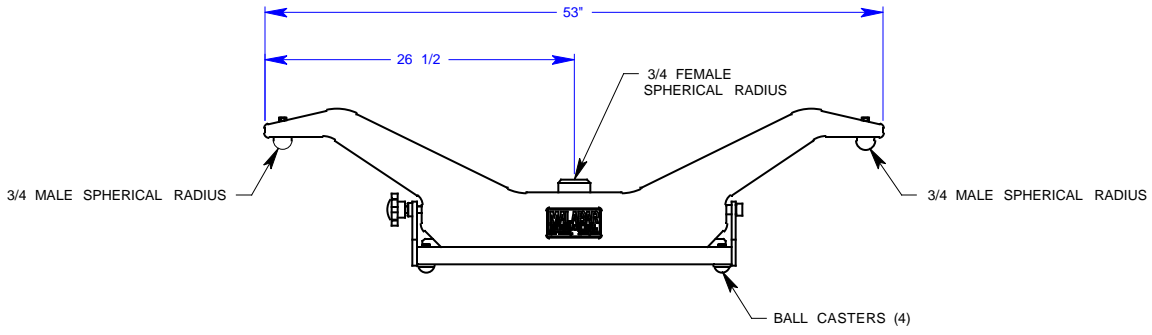

BEAM SHOWN IN JACKING POSITION

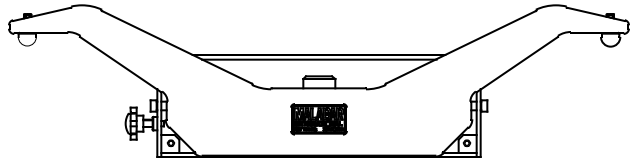

BEAM SHOWN IN ROTATED POSITION

**SPECIFICATIONS:**  
 RATED CAPACITY ..... 50 TONS / 45.4 M. TONS  
 PROOF LOAD ..... 70 TONS / 63.5 M. TONS  
 STANDARD PAINT ..... SKYDROL RESISTANT YELLOW  
 BEAM WEIGHT ..... 380 LBS / 172.4 Kg

MODEL : 8838

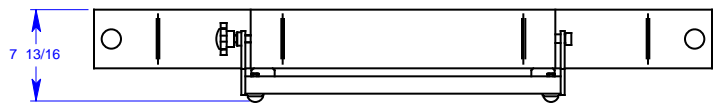
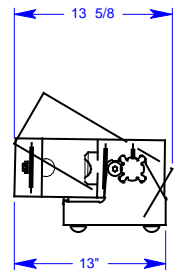

ITEM NO.	QTY.	PSGM. NO.	PART OR IDENTIFYING NO.	NOMENCLATURE OR DESCRIPTION	MATERIAL SPECIFICATION
PARTS LIST					
UNLESS OTHERWISE SPECIFIED DIMENSIONS ARE IN INCHES TOLERANCES ARE:		CONTRACT NO.		MALABAR INTERNATIONAL SIMI VALLEY, CALIFORNIA	
FRACTIONS DECIMALS ANGLES		APPROVAL		50 TON BEAM ASSEMBLY (B737-600/700/800)	
* 1/32 .001 .010 .015 .030 .060 .125 .250 .500 1.000		DRAWN BILL W. 1/98		DATE	
MATERIAL		CHECKED NICK A. 1/98		SCALE	
FINISH		ISSUED		SIZE PSGM. NO. DWGNO. SK 8838 REV	
NEXT ASSEMBLY USED ON		APPLICATION DO NOT SCALE DRAWING		SCALE 1/5 SHEET 1 OF 2	

NOTES : UNLESS OTHERWISE SPECIFIED

8 7 6 5 4 3

DWGNO. SK8838		SH 2	REV 1
REVISIONS			
ZONE	REV	DESCRIPTION	DATE BY APPROVED

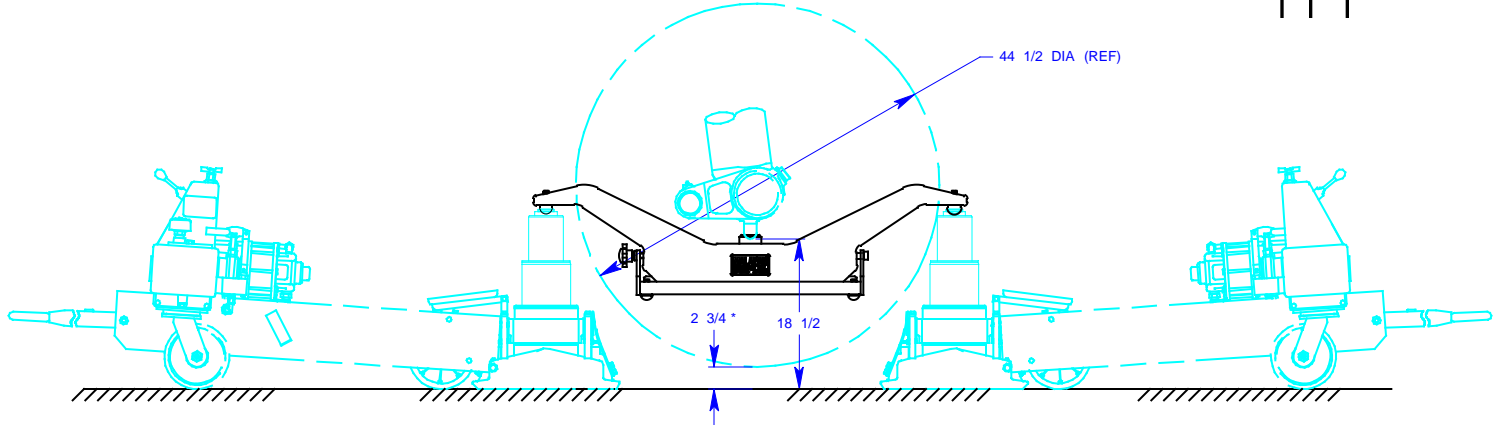

SCALE : NONE  
SHOWN IN RAISED POSITION

MALABAR AXLE JACK  
MODEL 65P10AR SHOWN.  
OTHER JACKS USABLE:  
60P10, 65P10, 50P9AR,  
85P10AR & 832R

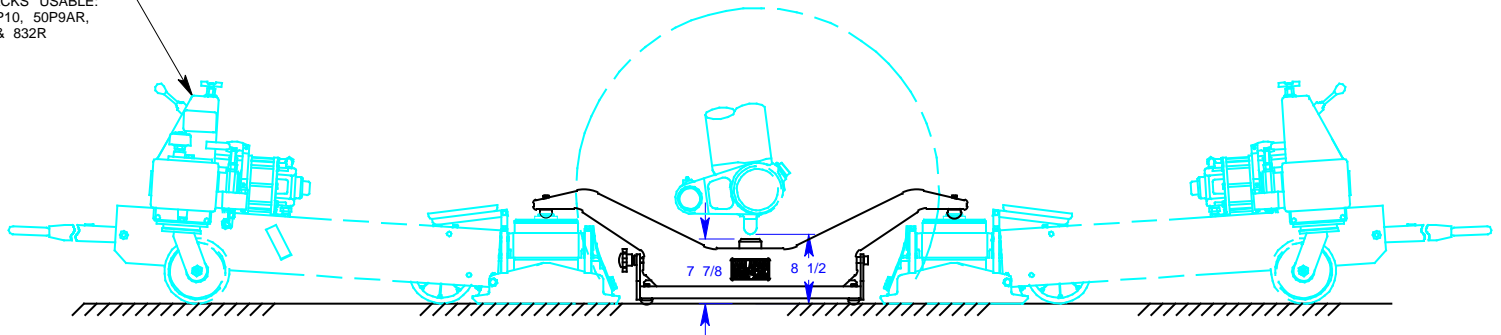

SCALE : NONE  
SHOWN IN DUAL FLAT CONDITION

MODEL : 8838

\* 50P9AR WILL PROVIDE 1 3/4 TIRE CLEARANCE  
ALL OTHER JACKS PROVIDE 2 3/4 TIRE CLEARANCE

NOTES : UNLESS OTHERWISE SPECIFIED

ITEM NO.	QTY	FSCM REGD. NO.	PART OR IDENTIFYING NO.	NOMENCLATURE OR DESCRIPTION	MATERIAL SPECIFICATION
PARTS LIST					
UNLESS OTHERWISE SPECIFIED DIMENSIONS ARE IN INCHES TOLERANCES ARE : FRACTIONS DECIMALS ANGLES				CONTRACT NO.	
1/32 .001 .015				APPROVAL DATE	
DRAWN				BILL W. 1/98	
CHECKED				NICK A. 1/98	
FINISH				ISSUED	
NEXT ASSEMBLY USED ON				SCALE 1/5	
APPLICATION				DO NOT SCALE DRAWING	
MALABAR INTERNATIONAL SIMI VALLEY, CALIFORNIA			PARTS LIST		
50 TON BEAM ASSEMBLY (B737-600/700/800)			DWGNO. SK 8838		
SIZE D 94861			SHEET 2 OF 2		

8 7 6 5 4 3 2 1