

45 Ton Axle Jack

Model 8842



The Model 8842 Axle Jack is a 45 ton capacity, three stage hydraulic jack designed primarily for use in jacking the main and/or nose landing gear of various aircraft. The jack consists of a three stage cylinder assembly, frame/reservoir assembly, valve block assembly, hand pump assembly and control console.

Model 8842 is built to withstand harsh environmental conditions, rugged use and to provide many years of continuous service. Our customers are guaranteed a quality product with each purchase and are assured of our continued product support whenever and wherever the need arises.

Standard Features:

- Hard chrome plated cylinder and plunger bores
- Single valve control for simple and easy aircraft raising and lowering
- Control console with all controls conveniently mounted for ease of operation
- 8 inch diameter heavy duty swivel casters and retractable front wheel with Skydrol resistant tread. The tow handle actuated front wheel provides improved ground clearance for towing.
- Hydraulic fuse at the cylinder assembly prevents lowering of load in the event of a fluid line failure
- Two manual hand pumps (one high pressure, low volume and one low pressure, high volume)
- Oil filter cap with filtered air vent and dipstick
- All unpainted parts are plated to resist corrosion
- Skydrol resistant paint (safety yellow)
- Factory proof load @ 150% of rated capacity
- 1 year standard warranty
- Fully enclosed shipping container with skid

Optional Features:

- Air-operated hydraulic pump
- Air retract (for fast plunger retraction)
- Load gauge for load indication (reads tons/psig)
- Long extension screw (1" extra low/extended height)
- Air line lubricator (for air operated hydraulic pump)
- Rain hat (covers cylinder assembly)
- Customer specified paint color

45 Ton Axle Jack

Model 8842

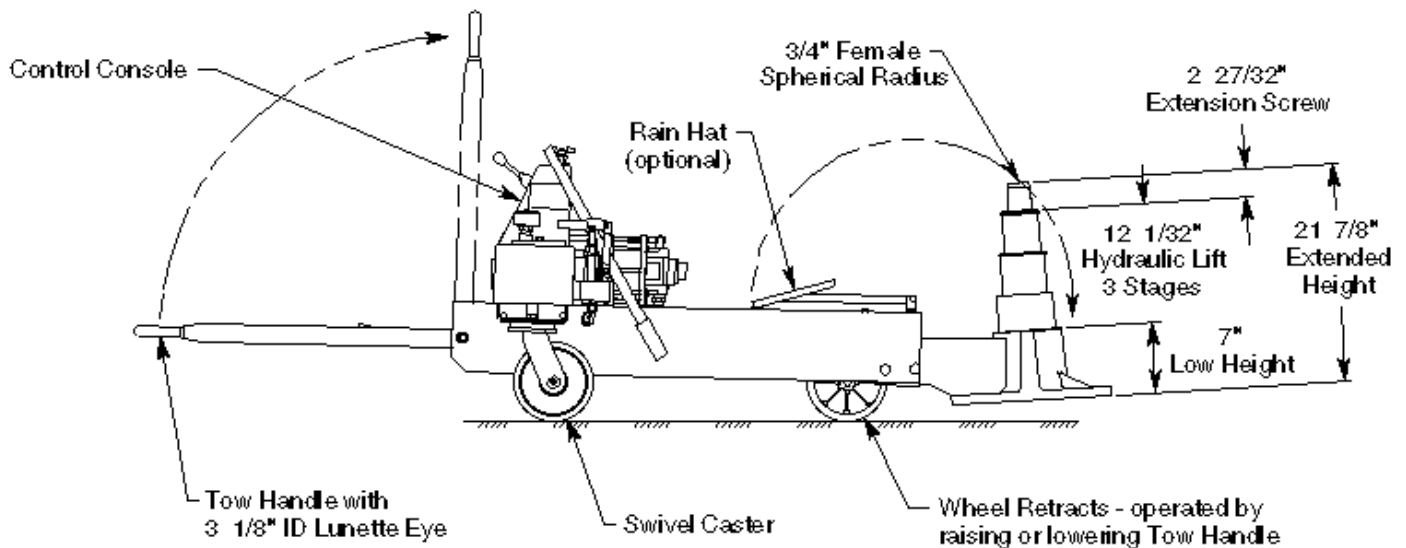
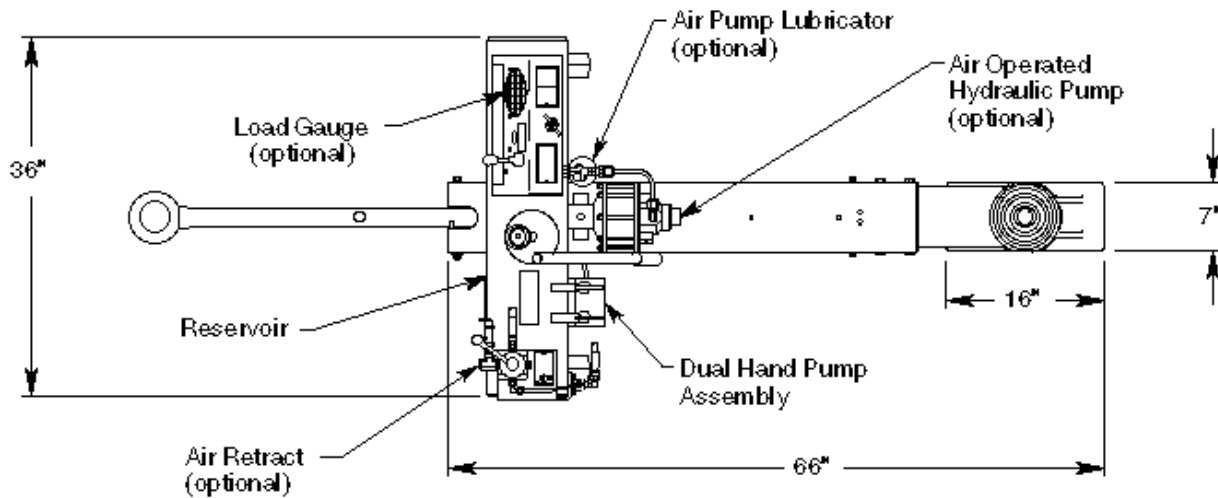

For more information contact: sales@malabar.com

45 Ton Axle Jack

Model 8842

Specifications:

Rated Capacity	45 tons (40.8 m. tons)
Side Load.....	15% of vertical load
Low Height:.....	7.00 inches (178 mm)
Hydraulic Lift.....	12.03 inches (306 mm)
Extension Screw.....	2.84 inches (72 mm)
Total Extended Height.....	21.88 inches (556 mm)
Base Width	7.00 inches (178 mm)
Cylinder Diameter.....	7.12 inches (181 mm)
Oil Pressure at Rated Capacity.....	7650 psig (538 kg/sq cm)
Safety Pop-off Valve set at:.....	47.3 tons (42.9 m. tons)
Proof Load	62.5 tons (56.7 m. tons)
Floor Loading at Rated Capacity.....	824 psi (58 kg/sq cm)
Reservoir Capacity	5.5 gallons (20.8 liters)
Hydraulic Fluid.....	MIL-PRF-5606 or equivalent
Maximum Towing Speed.....	5 mph (8 km/h)
Approximate Jack Net Weight.....	450 lbs (204 kg)

Model 8842 Typical Aircraft Applications:	
Main Landing Gear	Nose Landing Gear
A319, A320, A321, B717, B727, B737, B757, DC9, E190, E195, F100, MD80, MD90	A319, A320, A321, A330, A340-200/-300, B727, B737-300 THRU -900, B757, B767, B787

Optional Equipment Codes:

(Specify with order)

- AP: Air Operated Hydraulic Pump
- AR: Air Retract
- GA: Load Gauge
- LES: Long Extension Screw (add 1" extra to low/extended height)
- LU: Lubricator (requires air operated hydraulic pump)
- RH: Rain Hat
- RHLES: Rain Hat (compatible with long extension screw)
- SPC: Special Paint Color (yellow is standard)

45 Ton Axle Jack

Model 8842

Jack Accessories:

(Order separately)

- 8842PK: Repair Kit
- 871420: Tire Slave Kit (to operate air operated hydraulic pump from aircraft tire)
- 880470: Lift Ring Kit (provides three lift points to lift jack assembly)
- 881700: Model 8817 Universal Axle Jack Transporter (trailer for long distance, high speed towing)

Shipping Data:

NOTE: Unless otherwise specified, Model 8842 jack is shipped on a wood skid with an enclosed cover.
Refer to Malabar Axle Jack Shipping Supplement for additional packaging information.

Length inches (mm)	Width inches (mm)	Height inches (mm)	Weight lbs (kg)
75 (1905)	45 (1143)	34 (864)	510 (231)