

65 Ton Floating Auto-Retract™ Axle Jack

Model 8900



The Model 8900 Floating Auto-Retract Axle Jack is a 65 ton capacity, two stage hydraulic jack designed primarily for use in jacking the main and/or nose landing gear of various aircraft. The jack consists of a two stage cylinder assembly mounted on a spherical bearing (this bearing allows the jack ship adapter to follow the arc of the aircraft jack point, thus greatly reducing the stress on the jack's cylinder assembly as well as the aircraft axle and strut), base assembly, frame/reservoir assembly, valve block assembly, hand pump assembly and control console.

Model 8900 is built to withstand harsh environmental conditions, rugged use and to provide many years of continuous service. Our customers are guaranteed a quality product with each purchase and are assured of our continued product support whenever and wherever the need arises.

Standard Features:

- Patented floating cylinder assembly allows unit to track arc of landing gear jack point, eliminating excessive side loads on jack and landing gear thus providing safer operation and extending jack life
- Double acting auto-retract cylinder assembly incorporates a fluid bath for sealing surfaces to minimize corrosion and extend seal life. It also includes Skydrol resistant seals and bronze upper bearings for longer service life.
- Auto-retract plungers remain fully retracted while jack is being towed or in storage to protect against corrosion, contaminants and accidental damage
- Single valve control for simple and easy aircraft raising, lowering and auto-retract jack retracts to full retracted position automatically which provides for easy removal from under aircraft jack point after each operation
- Control console with all controls conveniently mounted for ease of operation
- Hydraulic fuse at the cylinder assembly prevents lowering of load in the event of a hose failure

Standard Features (cont.)

- 8 inch diameter heavy duty swivel casters and retractable front wheel with Skydrol resistant tread. Shock absorbing spring loaded front caster retracts automatically while jacking.
- Two manual hand pumps (one high pressure, low volume and one low pressure, high volume)
- Oil filter cap with filtered air vent and dipstick
- Hard chrome plated cylinder and plunger bores
- All unpainted parts are plated to resist corrosion
- Skydrol resistant paint (safety yellow)
- Factory proof load @ 150% of rated capacity
- 1 year standard warranty
- Fully enclosed shipping container with skid

Optional Features:

- Air operated hydraulic pump
- Load gauge for load indication (reads tons/psig)
- Air line lubricator (for air operated hydraulic pump)
- Rain hat (covers cylinder assembly)
- Customer specified paint color

For more information contact: sales@malabar.com

65 Ton Floating Auto-Retract™ Axle Jack Model 8900

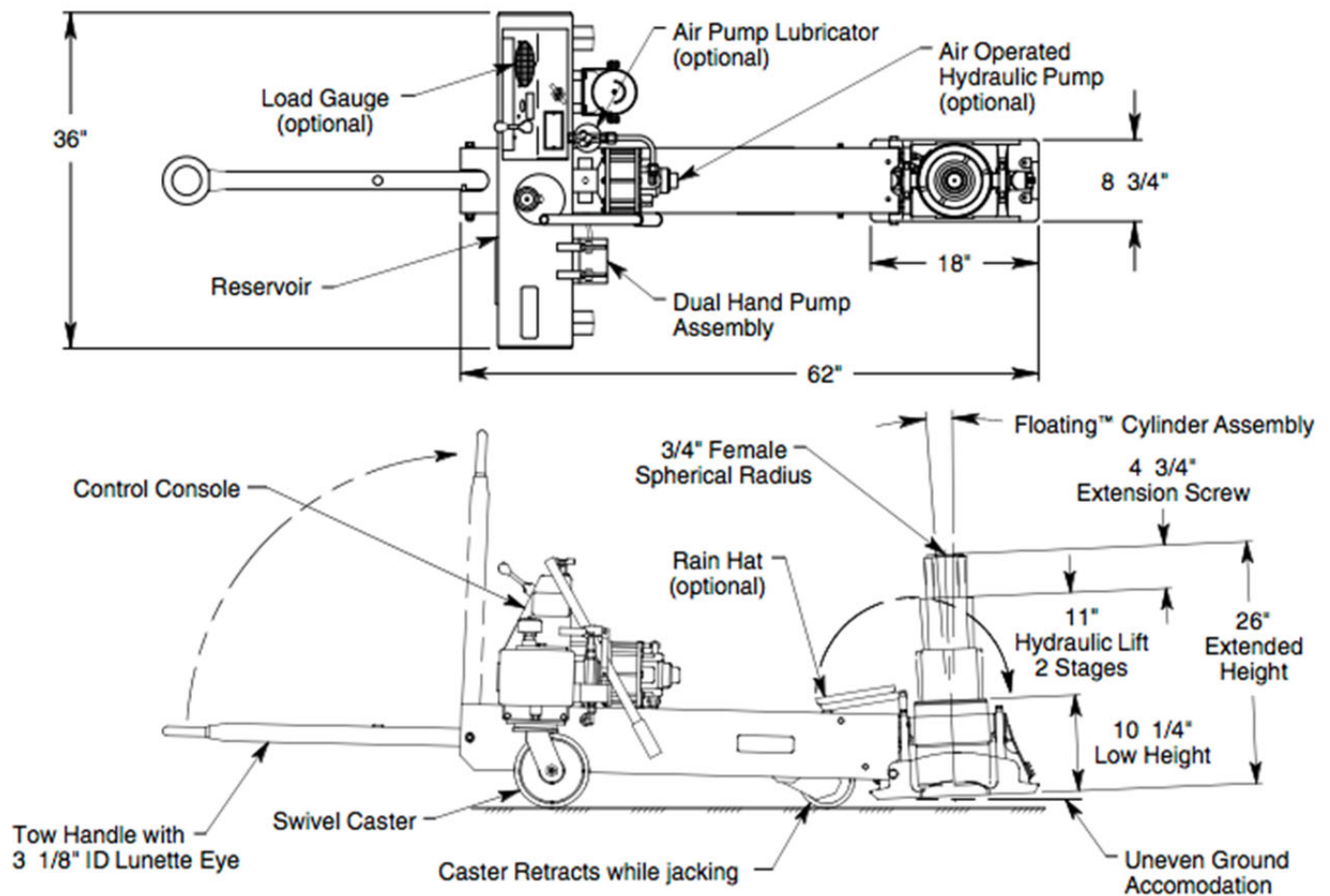

For more information contact: sales@malabar.com

65 Ton Floating Auto-Retract™ Axle Jack

Model 8900

Specifications:

Rated Capacity	65 tons (59.0 m. tons)
Low Height:	10.25 inches (260 mm)
Hydraulic Lift.....	11.00 inches (279 mm)
Extension Screw.....	4.75 inches (121 mm)
Total Extended Height.....	26.00 inches (660 mm)
Base Width	8.75 inches (222 mm)
Cylinder Diameter.....	8.00 inches (203 mm)
Oil Pressure at Rated Capacity	7000 psig (492 kg/sq cm)
Safety Pop-off Valve set at:	68.90 tons (62.5 m. tons)
Proof Load.....	97.50 tons (88.5 m. tons)
Floor Loading at Rated Capacity	825 psi (58 kg/sq cm)
Reservoir Capacity	5.5 gallons (20.8 liters)
Hydraulic Fluid.....	MIL-PRF-5606 or equivalent
Maximum Towing Speed.....	5 mph (8 km/h)
Approximate Jack Net Weight	500 lbs (227 kg)

Model 8900 Typical Aircraft Applications:	
Main Landing Gear	Nose Landing Gear
A300, A310, A319, A320, A321, A330 A340, B707, B717, B720, B727, B737 B747, B757, B767, B787, DC8, DC10, L1011, MD11	A300, A310, A330, A340, A350, B727, B747, B757, B767, B787, DC10, L1011, MD11

Optional Equipment Codes:

(Specify with order)

- AP: Air-Operated Hydraulic Pump
- GA: Load Gauge
- LU: Lubricator (requires air operated hydraulic pump)
- RH: Rain Hat
- SPC: Special Paint Color (yellow is standard)

65 Ton Floating Auto-Retract™ Axle Jack

Model 8900

Jack Accessories:

(Order separately)

- 8900PK: Repair Kit
- 871420: Tire Slave Kit (to operate air operated hydraulic pump from aircraft tire)
- 880470: Lift Ring Kit (provides three lift points to lift jack assembly)
- 881700: Model 8817 Universal Axle Jack Transporter (trailer for long distance, high speed towing)
- 873828: Extender Kit (for B747-400ER NLG)

Shipping Data:

NOTE: Unless otherwise specified, Model 8900 jack is shipped on a wood skid with an enclosed cover.
Refer to Malabar Axle Jack Shipping Supplement for additional packaging information.

Length inches (mm)	Width inches (mm)	Height inches (mm)	Weight lbs (kg)
70 (1778)	45 (1143)	34 (864)	560 (254)