

45 Ton “Fly-Away” Axle Jack

Model 8919



The Model 8919 “Fly-Away” Axle Jack is a 45 ton capacity three-stage telescoping hydraulic jack designed for use in aircraft maintenance. It consists of a three-stage cylinder assembly, hydraulic reservoir, two manual hand pumps for high and low pressure, and an air operated hydraulic pump for power operation.

The Model 8919 is built to withstand harsh environmental conditions and rugged use, and to provide many years of continuous service. Malabar customers are guaranteed a quality product with each purchase and are assured of continued product support whenever and wherever the need arises.

Standard Features:

- Hard chrome plated cylinder and plunger bores
- Extension screw and hand pump parts are plated to resist corrosion
- Two manual hand pumps (one high pressure, low volume; one low pressure, high volume)
- Air operated hydraulic pump for power operation
- Skydrol resistant paint (safety yellow)
- Factory proof load tested
- 1 year warranty
- Fully enclosed shipping container

Optional Features:

- Customer-specified paint color
- Permanent shipping and storage ATA enclosure

45 Ton “Fly-Away” Axle Jack Model 8919

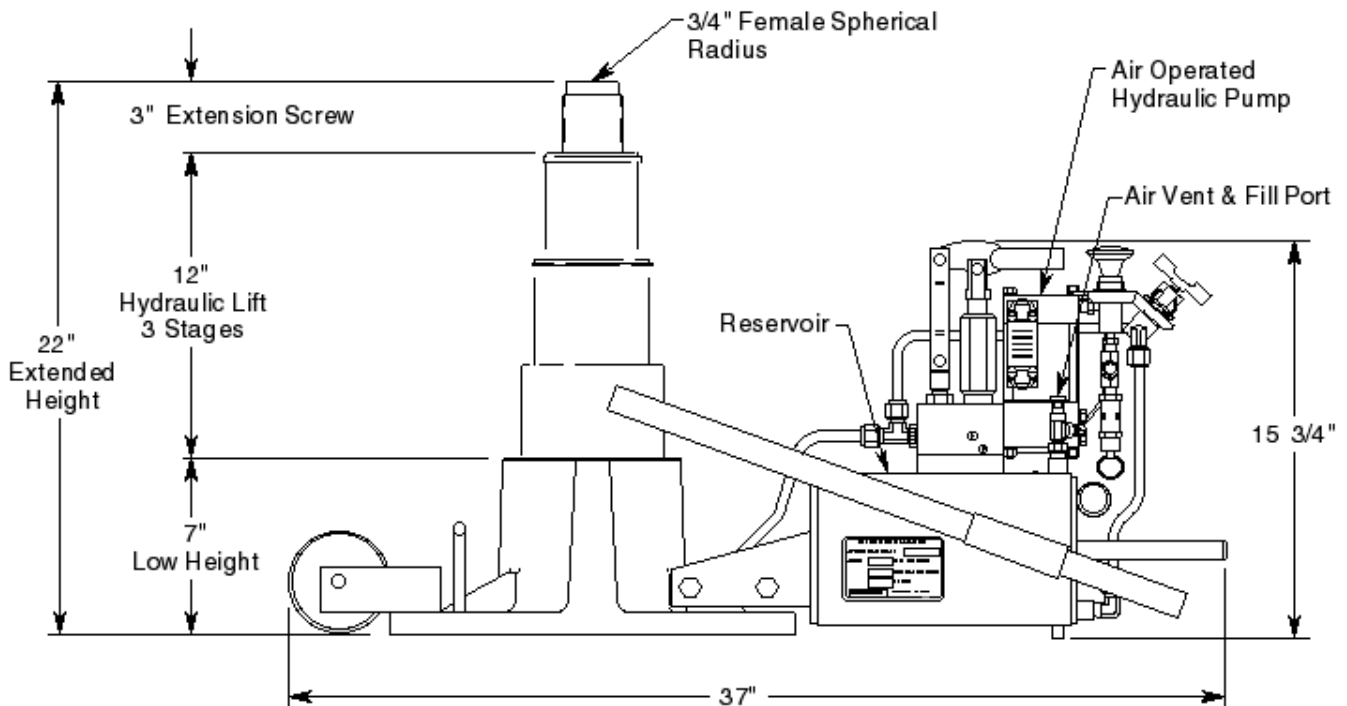
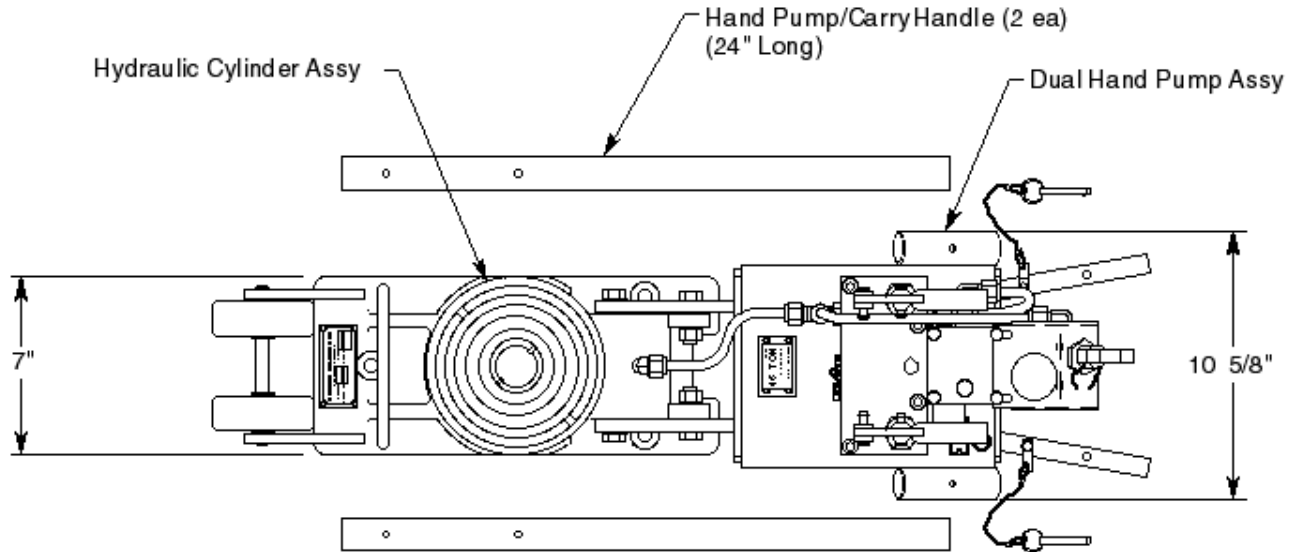

For more information contact: sales@malabar.com

45 Ton “Fly-Away” Axle Jack

Model 8919

Specifications:

Rated Capacity	45 tons (40.8 m. tons)
Side Load.....	15% of vertical load
Low Height.....	7.00 inches (178 mm)
Hydraulic Lift.....	12.00 inches (305 mm)
Extension Screw.....	3.00 inches (76 mm)
Total Extended Height.....	22.00 inches (559 mm)
Base Width	7.00 inches (178 mm)
Oil Pressure at Rated Capacity.....	7650 psig (538 kg/cm ²)
Safety Pop-Off Valve Set At.....	47.3 tons (42.9 m. tons)
Proof Load	62.5 tons (56.7 m. tons)
Reservoir Capacity	1.5 gallons (5.7 liters)
Hydraulic Fluid.....	MIL-PRF-5606 or equivalent
Approximate Jack Net Weight.....	195 lbs (89 kg)
Total Handle Load (Wheeling).....	50 lbs (23 kg)

Model 8919 Typical Aircraft Applications:

Main Landing Gear	Nose Landing Gear
A318, A319, A320, A321, B717, B727, B737, B757, C130, DC9, E190, E195, F100, MD80, MD90	A318, A319, A320, A321, B727, B737, B757, C130

Optional Equipment Codes:

(Specify with order)

- SPC: Special Paint Color (safety yellow is standard)
- 8919PK: Repair Kit
- 499-172: Permanent shipping and storage ATA enclosure
- 499-177: P-8A Permanent shipping and storage ATA enclosure

Shipping Data:

Note: Unless otherwise specified, Model 8919 jack is shipped in a fully enclosed shipping container.

Length inches (mm)	Width inches (mm)	Height inches (mm)	Weight lbs (kg)
42 (1067)	17 (432)	24 (610)	230 (104)