

95 Ton Floating “Fly-Away” Axle Jack

Model 8920

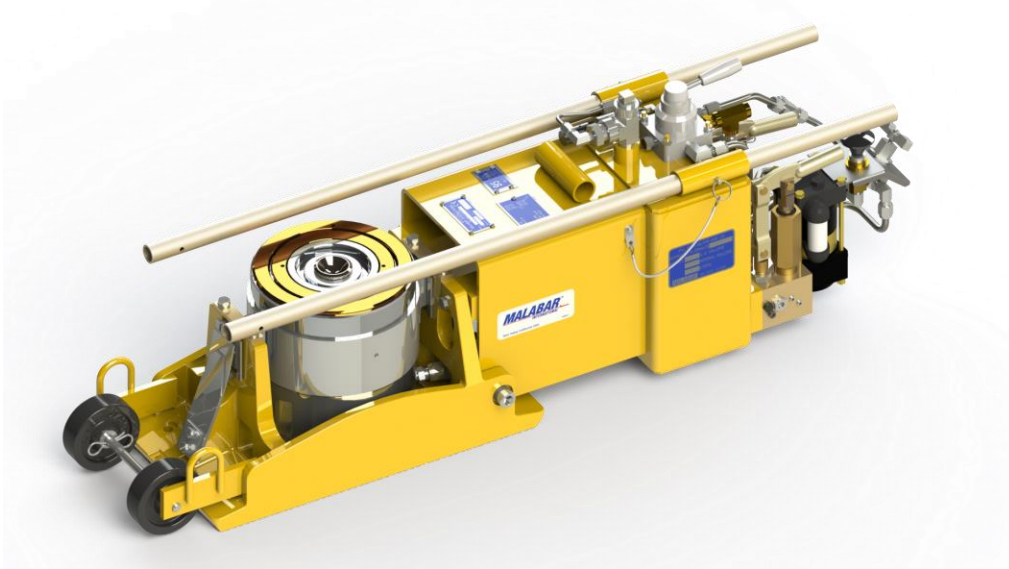

The Model 8920 Floating “Fly-Away” Axle Jack is a 95 ton capacity, two stage hydraulic jack designed primarily for use in jacking the main and/or nose landing gear of various aircraft. The jack consists of a two stage cylinder assembly mounted on a spherical bearing (this bearing allows the jack ship adapter to follow the arc of the aircraft jack point, thus greatly reducing the stress on the jack’s cylinder assembly as well as the aircraft axle and strut), base assembly, frame/reservoir assembly, valve block assembly, hand pump assembly, air retract and control console.

Model 8920 is built to withstand harsh environmental conditions, rugged use and to provide many years of continuous service. Our customers are guaranteed a quality product with each purchase and are assured of our continued product support whenever and wherever the need arises.

Standard Features:

- Patented floating™ cylinder assembly allows unit to track arc of landing gear jack point, eliminating excessive side loads on jack and landing gear thus providing safer operation and extending jack life
- Air retract for fast plunger retraction. Jack retracts to full retracted position, which provides for easy removal from under aircraft jack point after each operation.
- Hard chrome plated cylinder and plunger bores
- Extension screw and hand pump parts are plated to resist corrosion
- Two manual hand pumps (one high pressure, low volume and one low pressure, high volume)
- Air operated hydraulic pump for power operation
- Skydrol resistant paint (safety yellow)
- Factory proof load @ 150% of rated capacity
- 1 year standard warranty
- Fully enclosed shipping container

Optional Features:

- Permanent shipping and storage enclosure
- Customer specified paint color
- Repair kit

95 Ton Floating “Fly-Away” Axle Jack Model 8920

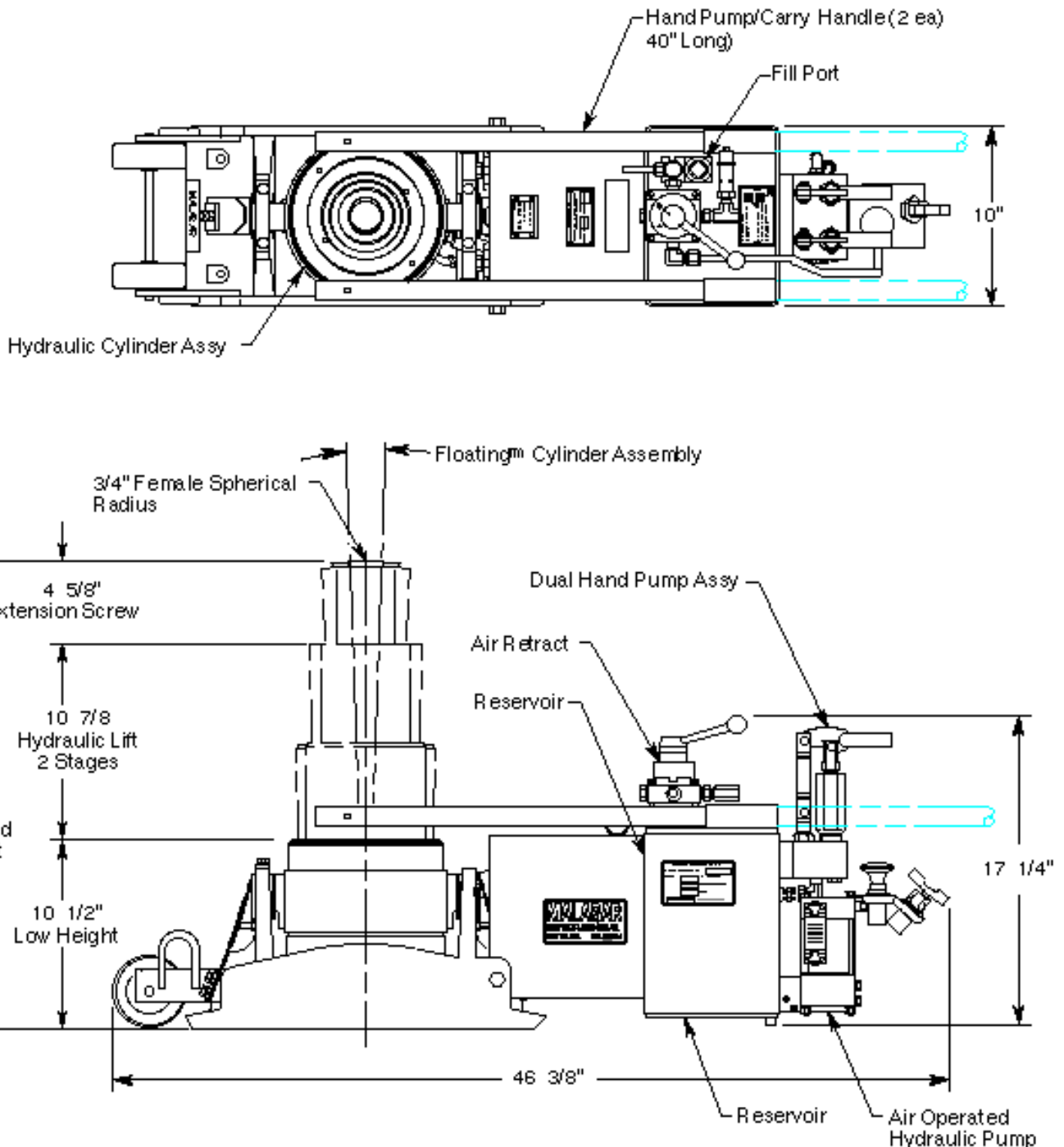

For more information contact: sales@malabar.com

95 Ton Floating “Fly-Away” Axle Jack Model 8920

Specifications:

Rated Capacity	95 tons (86 m. tons)
Side Load.....	15% of vertical load
Low Height.....	10.5 inches (267 mm)
Hydraulic Lift.....	10.88 inches (276 mm)
Extension Screw.....	4.62 inches (117 mm)
Total Extended Height.....	26 inches (660 mm)
Oil Pressure at Rated Capacity	8000 psig (562 kg/sq cm)
Safety Pop-off Valve set at:	101 tons (92 m. tons)
Proof Load	118 tons (107 m. tons)
Reservoir Capacity	2.8 gallons (10.7 liters)
Hydraulic Fluid.....	MIL-PRF-5606 or equivalent
Approximate Jack Net Weight.....	370 lbs (168 kg)
Total Handle Load (Wheeling).....	90 lbs (41 kg)

Model 8920 Typical Aircraft Applications:	
Main Landing Gear	Nose Landing Gear
A300, A310, A319, A320, A321, A330 A340, A350, A380**, B727, B737, B747, B747-8, B767, B777*, DC8, DC10, L1011, MD11	A300, A310, A330, A340, A350, A380**, B727, B747, B747-8, B767, B777, L1011
<p>*Two 8920 jacks are required for this application</p> <p>**Specify 1 ¼” Female Spherical Radius Ship Adapter p/n 885520 and at reduced aircraft axle jack load (less than 95 tons) for this application</p>	

Optional Equipment Codes:

(Specify with order)

- SPC: Special Paint Color (yellow is standard)
- 8920PK: Repair Kit
- 871420: Tire Slave Kit (to operate air-operated hydraulic pump from aircraft tire)
- 880428: 2-Inch Extender Kit (for B747-400ER & 747-8 NLG)
- 499-172: Permanent Shipping and Storage Enclosure

Shipping Data:			
NOTE: Model 8920 jack is shipped in a fully enclosed shipping container.			
Length inches (mm)	Width inches (mm)	Height inches (mm)	Weight lbs (kg)
49.5 (1257)	19.5 (495)	24.5 (622)	420 (191)