

95 Ton Floating Auto-Retract™ Axle Jack

Model 95P10AR



The Model 95P10AR Floating Auto-Retract Axle Jack is a 95 ton capacity, two stage hydraulic jack, designed primarily for use in jacking the main and/or nose landing gear of various aircraft. The jack consists of a two stage cylinder assembly mounted on a spherical bearing (this bearing allows the jack ship adapter to follow the arc of the aircraft jack point, thus greatly reducing the stress on the jacks cylinder assembly as well as the aircraft axle and strut), base assembly, frame/reservoir assembly, valve block assembly, hand pump assembly and control console.

Model 95P10AR is built to withstand harsh environmental conditions, rugged use and to provide many years of continuous service. Our customers are guaranteed a quality product with each purchase and are assured of our continued product support whenever and wherever the need arises.

Standard Features:

- Patented floating cylinder assembly allows unit to track arc of landing gear jack point, eliminating excessive side loads on jack and landing gear thus providing safer operation and extending jack life
- Double acting auto-retract cylinder assembly incorporates a fluid bath for sealing surfaces to minimize corrosion and extend seal life. It also includes Skydrol resistant seals and bronze upper bearings for longer service life.
- Auto-retract plungers remain fully retracted while jack is being towed or in storage to protect against corrosion, contaminants and accidental damage
- Single valve control for simple and easy aircraft raising, lowering and auto-retract. Jack retracts to full retracted position automatically which provides for easy removal from under aircraft jack point after each operation
- Control console with all controls conveniently mounted for ease of operation
- Hydraulic fuse at the cylinder assembly prevents lowering of load in the event of a hose failure
- Skydrol resistant paint (safety yellow)

Standard Features (cont.)

- 8 inch diameter heavy duty swivel casters and retractable front wheel with Skydrol resistant tread. The tow handle actuated front wheel provides improved ground clearance for towing.
- Two manual hand pumps (one high pressure, low volume and one low pressure, high volume)
- Oil filter cap with filtered air vent and dipstick
- Hard chrome plated cylinder and plunger bores
- All unpainted parts are plated to resist corrosion
- Factory proof load tested
- 1 year standard warranty
- Fully enclosed shipping container with skid

Optional Features:

- Standard air operated hydraulic pump
- High-speed air operated hydraulic pump
- Load gauge for load indication (reads tons/psig)
- Air line lubricator (for air operated hydraulic pump)
- Rain hat (covers cylinder assembly)
- Customer specified paint color

95 Ton Floating Auto-Retract™ Axle Jack Model 95P10AR

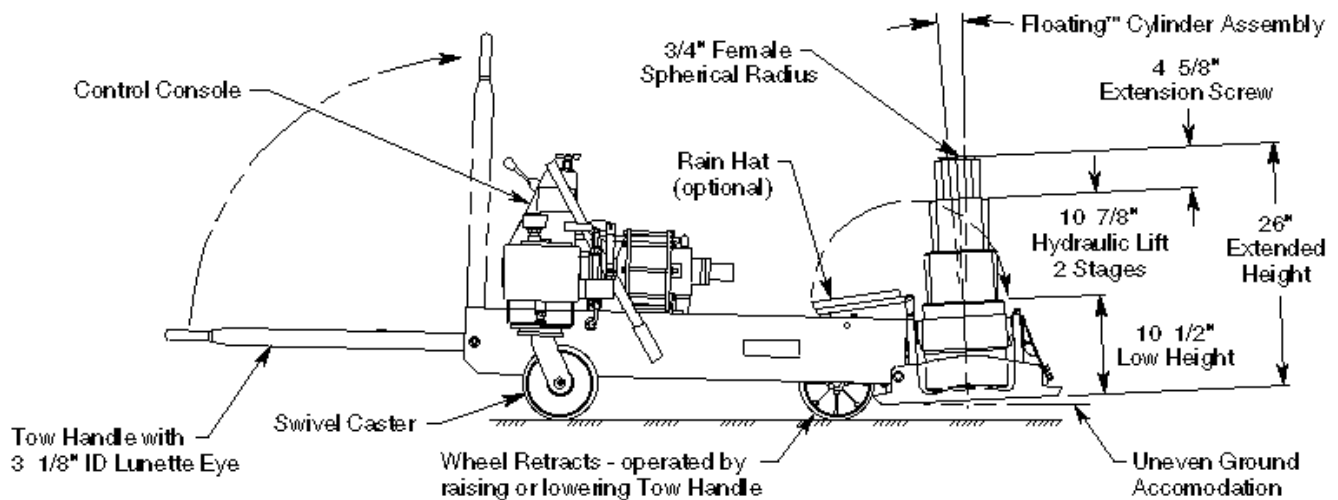
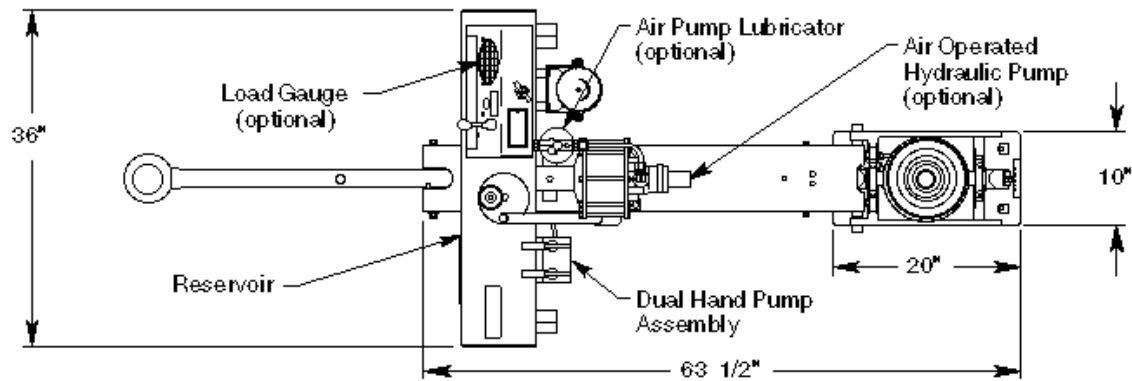

95 Ton Floating Auto-Retract™ Axle Jack

Model 95P10AR

Specifications:

Rated Capacity	95 tons (86.0 m. tons)
Low Height:	10.5 inches (267 mm)
Hydraulic Lift	10.88 inches (276 mm)
Extension Screw	4.62 inches (117 mm)
Total Extended Height	26 inches (660 mm)
Total Extended Height w/Extender Kit	28 inches (711 mm)
Base Width	10 inches (254 mm)
Cylinder Diameter	9 inches (229 mm)
Oil Pressure at Rated Capacity	8000 psig (562 kg/sq cm)
Safety Pop-off Valve set at:	101 tons (92 m. tons)
Proof Load	118 tons (107 m. tons)
Floor Loading at Rated Capacity	1000 psi (70 kg/sq cm)
Reservoir Capacity	5.5 gallons (20.8 liters)
Hydraulic Fluid	MIL-PRF-5606 or equivalent
Maximum Towing Speed	5 mph (8 km/h)
Approximate Jack Net Weight	580 lbs (263 kg)

Model 95P10AR Typical Aircraft Applications:

Main Landing Gear	Nose Landing Gear
A300, A310, A319, A320, A321, A330 A340, A350-900, A380**, B727, B737, B747, B747-8, B767, B777*, B787, DC8, DC10, L1011, MD11	A300, A310, A330, A340, A350-900, A380**, B727, B747, B747-8, B767, B777, B787, L1011
*Two 95P10AR jacks are required for this application **Specify 1 ¼" Female Spherical Radius Ship Adapter p/n 885520 at a reduced aircraft axle jack load (less than 95 tons) for this application	

Optional Equipment Codes:

(Specify with order)

- LP: Standard Air Operated Hydraulic Pump
- HP: High Speed Air Operated Hydraulic Pump
- GA: Load Gauge
- LPLU: Lubricator (requires standard air operated hydraulic pump)
- HPLU: Lubricator (requires high speed air operated hydraulic pump)
- RH: Rain Hat
- SA: Ship Adapter p/n 885520 (1 ¼" female spherical radius)
- SPC: Special Paint Color (yellow is standard)

95 Ton Floating Auto-Retract™ Axle Jack

Model 95P10AR

Jack Accessories:

(Order separately)

- 95P10ARPK: Repair Kit
- 871420: Tire Slave Kit (to operate air-operated hydraulic pump from aircraft tire)
- 880470: Lift Ring Kit (provides three lift points to lift jack assembly)
- 881700: Model 8817 Universal Axle Jack Transporter (trailer for long-distance, high-speed towing)
- 880428: 2-inch Extender Kit (for B747-400ER & 747-8 NLG)

Shipping Data:

NOTE: Unless otherwise specified, Model 95P10AR jack is shipped on a wood skid with an enclosed cover. Refer to Malabar Axle Jack Shipping Supplement for additional packaging information.

Length inches (mm)	Width inches (mm)	Height inches (mm)	Weight lbs(kg)
70 (1778)	45 (1143)	34 (864)	640 (290)