

# Aircraft Wheel/Brake Changer

## Model 175M



The Model 175M Aircraft Wheel/Brake Changer is capable of changing aircraft tires and wheel assemblies from 34 to 56 inches O.D. The Brake Cradle (BC300P, BC400P, BC500P) is required for brake change operations. The Wheel/Brake Changer consists of a Bottle Jack, Tilt Adjustment Screw, Inner and Outer Frames, and Wheel Hold Down Steel Chain.

The Model 175M is built to withstand harsh environmental conditions and rugged use, and to provide many years of continuous service. Our customers are guaranteed a quality product with each purchase and are assured of our continued product support whenever and wherever the need arises.

### Standard Features:

- Cad plated steel rollers with oil-embedded bearings to support wheels or brake cradle and discs
- Bottle jack with hand pump for vertical lift
- Adjustment screw for fore and aft tilt
- Chain for securing wheel
- Three medium duty swivel casters
- Skydrol resistant paint (safety yellow)
- Shipment on domestic skid
- One year standard warranty

### Optional Features:

- Customer specified paint color
- Export crating

# Aircraft Wheel/Brake Changer

## Model 175M

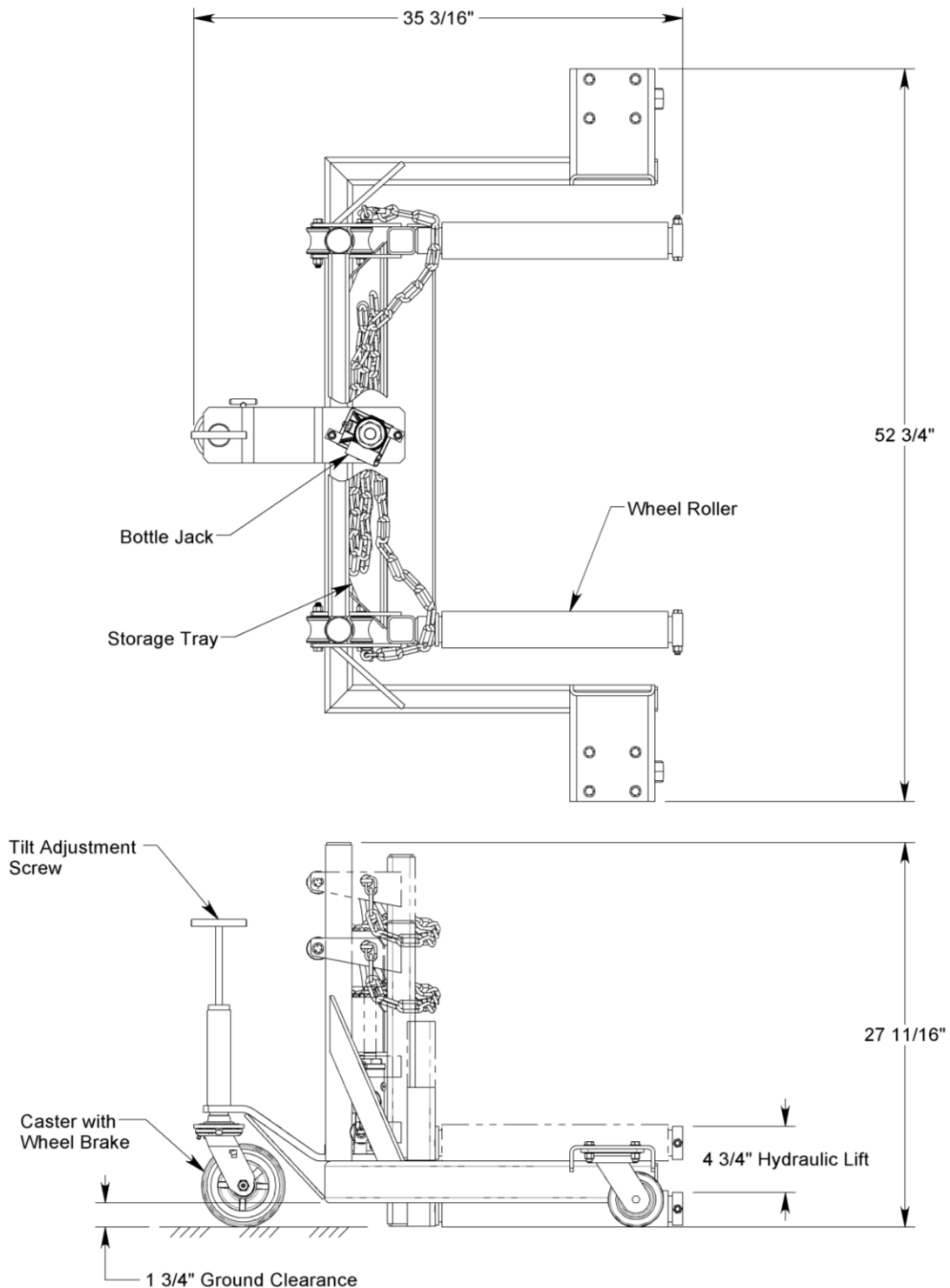

For more information contact: [sales@malabar.com](mailto:sales@malabar.com)

# Aircraft Wheel/Brake Changer

## Model 175M

### Specifications:

Wheel Changer Rated Capacity.....	700 lbs (318 kg)
Total Lift.....	4.75 inches (121 mm)
Tilt Fore and Aft.....	± 3°
Proof Load.....	900 lbs (408 kg)
Approximate Net Weight.....	275 lbs (125 kg)
Optional Brake Cradle Rated Capacity.....	600 lbs (272 kg)
Brake Cradle Unit Weight.....	40 lbs (18 kg)
Tire Diameter Range.....	34" to 56" (864 to 1422 mm)

### Model 175M Typical Aircraft Applications:

Main Gear Wheels	Nose Gear Wheels	Brake Cradle (Specify Model)
A300, A310, B707, B727, B757, B767	A300, A310, B707, B757, B767	BC400P
A319, A320, A321, B717, B737	N/A	BC400P
F70, F100	N/A	BC300P
A330, A340, A350, B747, B777, B787, DC10, MD11, L1011	A330, A340, A350, B747, B777, B787, DC10, MD11, L1011	BC500P
DC8, DC9, MD80-90	DC8	BC400P

### Optional Equipment Codes:

*(Specify with order)*

SPC: Special Paint Color

### Optional Accessory Codes:

*(Specify with order)*

- BC300P: Brake Cradle with Rubber Pad, p/n 871200P
- BC400P: Brake Cradle with Rubber Pad, p/n 871100P
- BC500P: Brake Cradle with Rubber Pad, p/n 871000P

# Aircraft Wheel/Brake Changer

## Model 175M

### Optional Packaging Codes:

(Specify with order)

- : Domestic Skid
- EC: Export Crate (Additional Cost)

### Shipping Data:

NOTE: Weight includes optional Brake Cradle.

Packaging Code	Length inches (mm)	Width inches (mm)	Height inches (mm)	Weight lbs (kg)
-	54 (1372)	41 (1041)	35 (889)	365 (166)
EC	56 (1422)	45 (1143)	38 (965)	540 (245)