

20 Ton “Fly-Away” Axle Jack

Model 8966

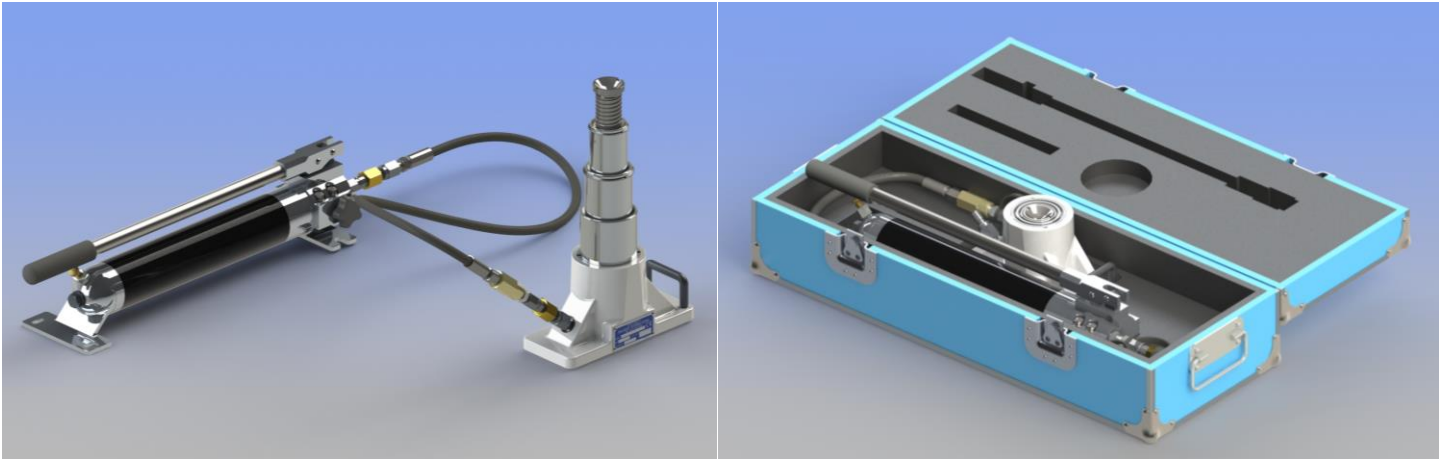

The Model 8966 “Fly-Away” Axle Jack is a 20 ton capacity three stage hydraulic jack designed for use in aircraft maintenance. It consists of a three stage cylinder assembly, hydraulic reservoir, and hand pump. A lifting handle is also supplied for ease of handling.

The Model 8966 is built to withstand harsh environmental conditions and rugged use, and to provide many years of continuous service. Our customers are guaranteed a quality product with each purchase and are assured of our continued product support whenever and wherever the need arises.

Standard Features:

- Two stage hand pump for rapid cylinder extension (low pressure/high volume and high pressure/low volume)
- Hard chrome plated cylinder and plunger bores
- All unpainted parts are plated to resist corrosion
- Skydrol resistant paint (white)
- Factory proof load @ 150% of rated capacity
- Fully enclosed shipping container
- 1 year standard warranty

Optional Features:

- Customer-specified paint color
- Permanent shipping and storage ATA enclosure

20 Ton “Fly-Away” Axle Jack

Model 8966

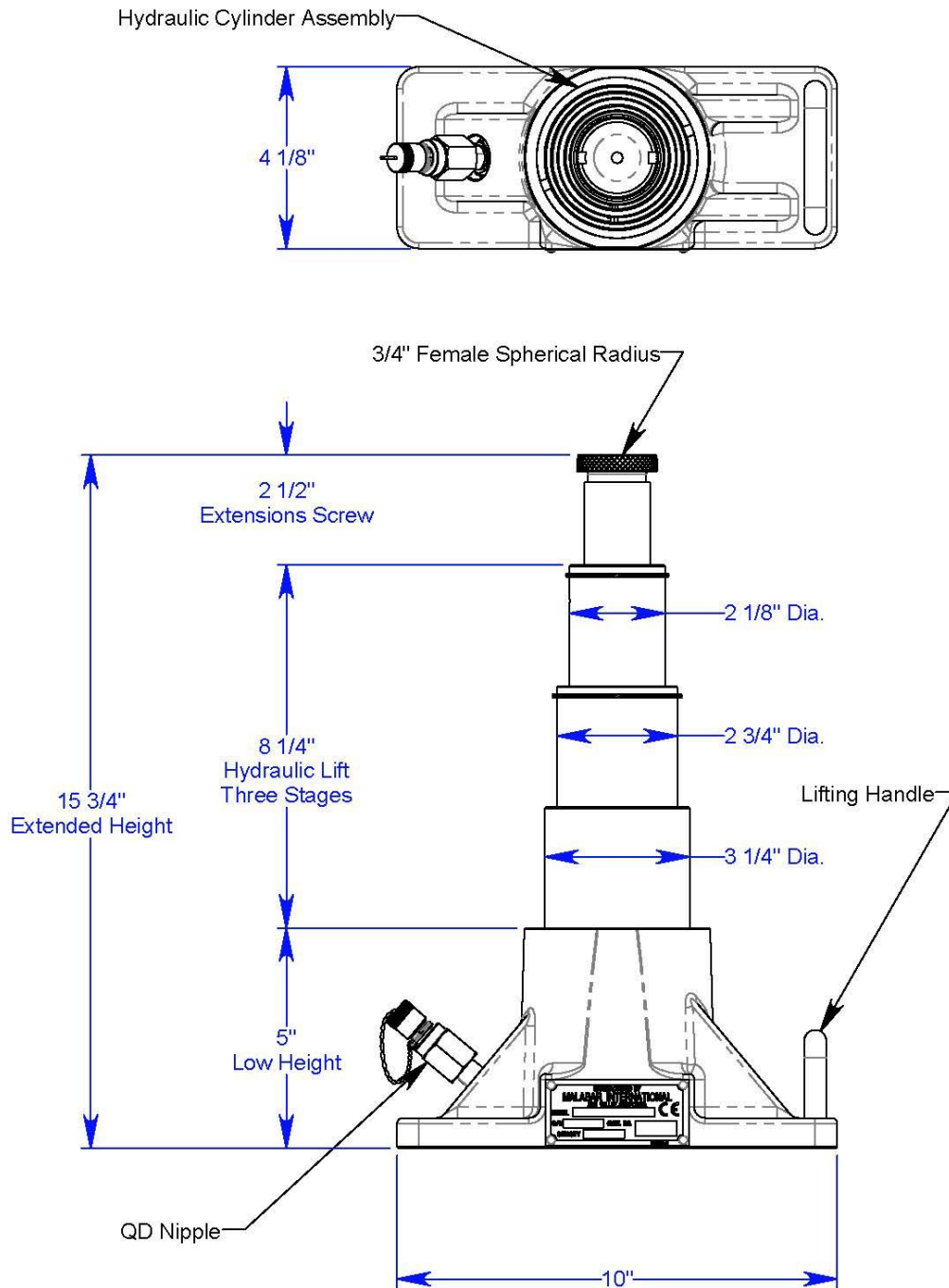

For more information contact: sales@malabar.com

20 Ton “Fly-Away” Axle Jack

Model 8966

Specifications:

Rated Capacity	20 tons (18.1 m. tons)
Side Load.....	15% of vertical load
Low Height.....	5.00 inches (127 mm)
Hydraulic Lift.....	8.25 inches (210 mm)
Extension Screw.....	2.50 inches (64 mm)
Total Extended Height.....	15.75 inches (400 mm)
Oil Pressure at Rated Capacity	9083 psig (639 kg/cm ²)
Safety Pop-off Valve set at.....	22.0 tons (20.0 m. tons)
Proof Load	30.0 tons (27.2 m. tons)
Reservoir Capacity	0.30 Gallons (1.15 liters)
Hydraulic Fluid.....	MIL-PRF-5606 or equivalent
Approximate Jack Net Weight.....	35 lbs (16.0 kg)

Model 8966 Typical Aircraft Applications:

Nose Landing Gear	Main Landing Gear
A319*, A320*, A321*, B717, B737, DC9, MD80, MD90, CRJ, DASH 8, Q400, GLOBAL EXPRESS, CHALLENGER, EMB 145/175/190/195	CRJ, DASH 8, Q400, GLOBAL EXPRESS, CHALLENGER, EMB 145/175/190/195
*Routine and dual flats	

Optional Equipment Codes:

(Specify with order)

- SPC: Special paint color (white is standard)
- 8966PK: Repair Kit
- PSE: Permanent storage enclosure P/N 896650

Shipping Data:

Length inches (mm)	Width inches (mm)	Height inches (mm)	Weight lbs (kg)
30" (762)	11 ¼" (286)	12 ¼" (311)	64 (29.0)