

# 12 Ton Axle Jack

## Model 642S

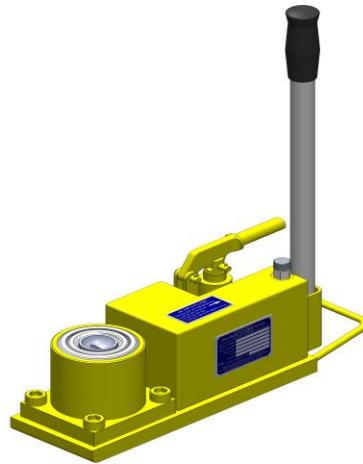

The Model 642S Axle Jack is a 12 ton capacity, two stage hydraulic jack designed primarily for use in jacking main and/or nose landing gear of various aircraft. The jack consists of a three stage cylinder assembly, hydraulic reservoir and hand pump assembly. Lifting handle is also supplied for ease of handling.

Model 642S is built to withstand harsh environmental conditions and rugged use, and to provide many years of continuous service. Our customers are guaranteed a quality product with each purchase and are assured of our continued product support whenever and wherever the need arises.

### Standard Features:

- Hard chrome plated cylinder and plunger bores
- Extension screw and hand pump parts are plated to resist corrosion
- Manual hand pump
- Skydrol resistant paint (safety yellow)
- Factory proof load @ 150% of rated capacity
- 1 year standard warranty
- Fully enclosed shipping container

### Optional Features:

- Customer specified paint color
- Repair kit

# 12 Ton Axle Jack

## Model 642S

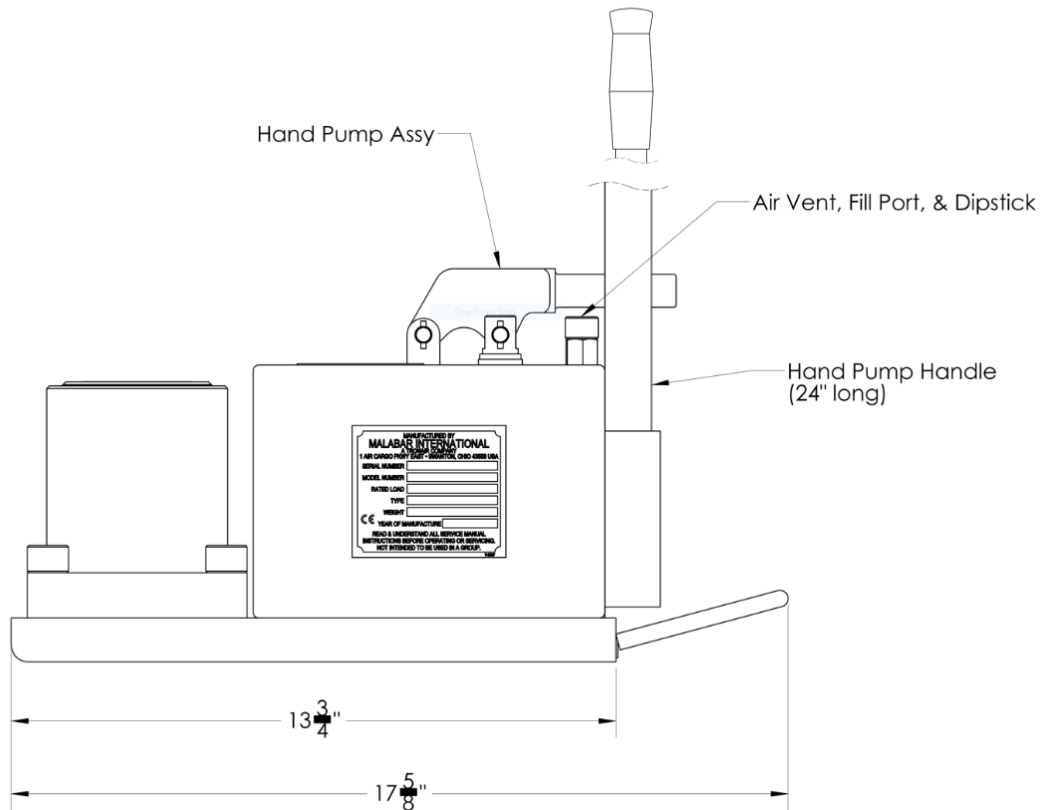
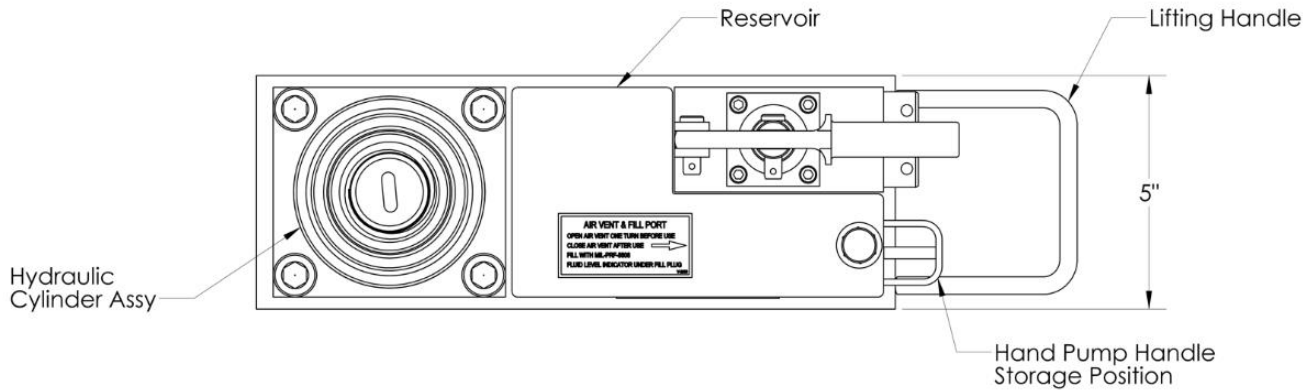

# 12 Ton Axle Jack

## Model 642S

### Specifications:

Rated Capacity .....	12 tons (10.9 m. tons)
Side Load.....	15% of vertical load
Low Height.....	6.38 in. (16.2 cm)
Hydraulic Lift.....	7.93 in. (20.1 cm)
Extension Screw.....	2.68 in. (6.8 cm)
Total Extended Height.....	17 in. (432 mm)
Oil Pressure at Rated Capacity .....	4237 psig (298 kg/sq cm)
Safety Pop-off Valve set at:.....	13.2 tons (12.0 m. tons)
Proof Load .....	18 tons (16.3 m. tons)
Reservoir Capacity .....	0.6 gallons (2.1 liters)
Hydraulic Fluid.....	MIL-PRF-5606 or equivalent
Approximate Jack Net Weight.....	58 lbs. (26 kg)

### Model 642S Typical Aircraft Applications:

Nose Landing Gear	Main Landing Gear
A318, A319, A320, A321, ARJ21, ATR42, ATR72, Avro RJ, B717, B737, BAC1-11, BAE146, CL601, CL602, CL604, CL605, CL610, CS100, CS300, D228, D328, Dash 7, Dash 8, DC9, DHC5, DHC6, Embraer Legacy 450/500/600/650, ERJ-135/-145/-170/-175/-190/-195, F27, F28, F50, F100, Falcon 10, Falcon 20, Falcon 50, Falcon 100, Global Express, HS125, Jetstar, Learjet 45, Learjet 75, MD80, MD90, S330, S360, SF340	ATR42, ATR72, D228, D328, Dash 7, Dash 8, DHC5, DHC6, Dornier 228/328, Embraer Legacy 450/500/600/650, F27, F50, Falcon 10, Falcon 20, Falcon 50, Falcon 100, Jetstar, Learjet 45, Learjet 75, S330, S360, SF340

### Optional Equipment Codes:

*(Specify with order)*

SPC: Special Paint Color (yellow is standard)

642SPK: Repair Kit

### Shipping Data:

NOTE: Model 642S jack is shipped in a fully enclosed shipping container.

Length inches (mm)	Width inches (mm)	Height inches (mm)	Weight lbs (kg)
25 (635)	10 (254)	17 (432)	44 (20)

